

# HS 252 - STANDARD ASSEMBLY TORQUES

## TABLE OF CONTENTS

1	SCOPE .....	8
2	PURPOSE.....	8
3	DOCUMENT CONTROL .....	8
4	REFERENCES .....	8
5	WARNINGS.....	9
6	APPLICATIONS .....	9
6.1	APPLICATION NOTES .....	12
7	TORQUE TOLERANCES .....	12
8	LINK TO HS DOCUMENTS.....	12
9	HGT-80 STANDARD (SCREWS AND THREADED RODS - 80% PRELOAD).....	13
10	HGT-50 STANDARD (SCREWS AND THREADED RODS - 50% PRELOAD).....	14
11	HGT-35 STANDARD (SCREWS - 35% PRELOAD) .....	15
12	HGT-SS STANDARD (SET SCREWS).....	16
13	HGT-LHCS STANDARD (LOW HEAD CAP SCREWS) .....	17
14	HGT-FT STANDARD (FITTINGS) .....	18
14.1	IMPORTANT NOTES.....	18
15	HGT-EL STANDARD (ELECTRICAL APPLICATIONS).....	23
16	DRAWING SPECIFICATIONS .....	24
17	SUPPLIER RECOMMENDED TORQUE SPECIFICATIONS.....	26
17.1	HYDRAULIC MANIFOLDS – TORQUE VALUES FOR SCREWS .....	26
17.2	HYDRAULIC MANIFOLDS – TORQUE VALUES FOR ORIFICES .....	26
17.3	HOSE/PIPE CLAMPS – TORQUE VALUES FOR SCREWS .....	27
17.4	HYDRAULIC MOTORS – TORQUE FOR MOUNTING BOLTS .....	28
17.5	BOSCH REXROTH DBDS PRESSURE RELIEF VALVES .....	28
17.6	BLADDER ACCUMULATOR NECK ADAPTOR SPECIFICATIONS .....	29
17.7	HYDAC OIL LEVEL SIGHT GAUGE .....	29
17.8	HYDAC PRESSURE TRANSDUCERS .....	29
17.8.1	Hydac Differential Pressure Transmitter .....	29
17.9	DANFOSS PRESSURE TRANSDUCER.....	29
17.10	NUMATICS AIR VALVE ASSEMBLY TORQUE SPECIFICATIONS .....	30
17.10.1	Torque Specifications for Numatics 2012 & 2035 Air Valve Assemblies.....	30

17.10.2	Torque Specifications for Numatics ISO 1, 2 & 3 Air Valve Assemblies .....	31
17.11	HYDAC MALE PRESSURE TEST POINT .....	31
17.12	ACCUMULATOR GAS VALVES .....	32
17.13	EV9 FLOW CONTROL VALVE .....	32
17.14	IGUS CFX CLAMPS .....	32
17.15	VIBRATION MOUNTS .....	33
18	INTERNATIONAL STANDARDS TORQUE SPECIFICATIONS .....	33
18.1	ISO 6162:1994 - SPLIT FLANGE ASSEMBLIES .....	33
18.2	CAUTION .....	33
18.3	NOTES .....	33
19	PET MOLD AND HOT RUNNER SPECIAL TORQUE SPECIFICATIONS .....	33
19.1	CAM FOLLOWER TORQUE SPECIFICATIONS .....	34
19.2	EOAT TUBE RETAINER PIN TORQUE SPECIFICATION .....	34
19.3	COOLPIK VACUUM/BLOW PIN TORQUE SPECIFICATIONS .....	34
19.4	COOLPIK MOVING PUCK INSTALLATION TORQUE SPECIFICATION .....	35
19.5	COOLPIK PLATE MOUNTING TORQUE SPECIFICATION .....	35
19.6	MOLD/HOT RUNNER LIFT BARS MOUNTING SCREWS TORQUE APPLICATIONS .....	36
19.7	GIB/WEAR PLATE MOUNTING SCREWS TORQUE SPECIFICATION .....	36
19.8	NECK RING PLUGS TORQUE SPECIFICATION .....	36
19.9	STACK INSERTS TORQUE SPECIFICATION .....	36
19.10	TORQUE SPECIFICATION FOR WATER MANIFOLDS TO SLIDES .....	37
19.11	TORQUE SPECIFICATION FOR SLIDE TO CONNECTING BARS .....	37
19.12	TORQUE SPECIFICATION FOR EOAT ASSY. TO ROBOT .....	37
19.13	TORQUE SPECIFICATION FOR NEXPET CORE SLEEVE SET SCREWS .....	37
20	APPENDIX .....	37
20.1	DLO DEVICE DETAILS (2205) .....	38

## TABLE OF FIGURES

Figure 1 – Husky General Torque (HGT) - Standard Applications (# 1 to 8) .....	10
Figure 2 – Using Hex Tool Adapter to Access Mold Mounting Screws .....	11
Figure 3 – Individual Torque Specifications .....	24
Figure 4 – Husky General Torque Chart .....	25
Figure 5 – Numatics 2012 & 2035 Air Valve Assemblies .....	30

Figure 6 – Numatics ISO 1, 2 & 3 Air Valve Assemblies..... 31

Figure 7 – EOAT Tube Retainer Pin Torque Specification..... 34

Figure 8 – Moving Puck Assembly Installation Torque Specification..... 35

Figure 9 – COOLPIK Assembly on Machine Plenum ..... 35

Figure 10 – Torque Specification for NexPET Core Sleeve Set Screws ..... 37

## TABLE OF TABLES

Table 1 – Husky General Torque (HGT) - Standard Applications..... 10

Table 2 – HGT-80 Metric Fasteners ..... 13

Table 3 – HGT-80 Imperial Fasteners ..... 13

Table 4 – HGT-50 Metric Fasteners ..... 14

Table 5 – HGT-50 Imperial Fasteners ..... 14

Table 6 – HGT-35 Metric Fasteners ..... 15

Table 7 – HGT-35 Imperial Fasteners ..... 15

Table 8 – HGT-SS Metric Set Screws ..... 16

Table 9 – HGT-SS Imperial Screws ..... 16

Table 10 – HGT-LHCS Metric Low Head Cap Screws ..... 17

Table 11 – HGT-FT ORFS Tube Ends ..... 19

Table 12 – HGT-FT ORFS Hose Ends (Manuli Hose Fittings) ..... 19

Table 13 – HGT-FT SAE and BSPP Ends..... 20

Table 14 – HGT-FT JIC Ends..... 20

Table 15 – HGT-FT NPT and BSPT Plugs and Fittings ..... 21

Table 16 – HGT-FT Flareless Tube Ends..... 21

Table 17 – HGT-FT SAE Plugs..... 21

Table 18 – HGT-FT Bulkhead Locknuts ..... 21

Table 19 – HGT-FT BSPP Plugs ..... 22

Table 20 – HGT-FT Metric Plugs..... 22

Table 21 – HGT-EL Metric and Imperial Screws, Mounting Hardware (Electrical Applications)  
..... 23

Table 22 – HGT-EL Heater Bands (Electrical Applications)..... 23

Table 23 – HGT-EL Solid State Relays (Electrical Applications) ..... 24

Table 24 – HGT-EL Premolded Cables (Electrical Applications) ..... 24

Table 25 – HGT-EL Electrical Cabinet Door Ground Stud (Electrical Applications).....	24
Table 26 – Torque for Hydraulic Valves Mounting Bolts.....	26
Table 27 – Torque for Orifices on Hydraulic Manifolds.....	26
Table 28 – Torque for Stauff or Hydac Hose/Pipe Clamps Mounting Bolts.....	27
Table 29 – Torque for Stopflex Hose Bands Mounting Bolts.....	27
Table 30 – Heavy-Duty Hose Clamp (T-Bolt Style).....	28
Table 31 – Torque for Diffuser Hose Clamp.....	28
Table 32 – Torques for Hydraulic Motors Mounting Bolts.....	28
Table 33 – Bosh Rexroth DBDS Pressure Relief Valves.....	28
Table 34 – Bladder Accumulator Neck Adaptor Specifications.....	29
Table 35 – Numatics 2012 & 2035 Air Valve Assemblies.....	30
Table 36 – Numatics ISO 1, 2 & 3 Air Valve Assemblies.....	31
Table 37 – Code 61 Split Flange Assemblies.....	33
Table 38 – Code 62 Split Flange Assemblies.....	33
Table 39 – CAM Follower Torque Specifications.....	34
Table 40 – EOAT Tube Retainer Pin Torque Specification.....	34
Table 41 – COOLPIK Vacuum/Blow Pin Torque Specifications.....	34
Table 42 – Mold/Hot Runner Lift Bars Mounting Screws Torque Specifications.....	36
Table 43 – Neck Ring Plugs Torque Specifications.....	36

## REVISION LOG

Rev.	Remarks
79	Added Table 31 – Torque for Diffuser Hose Clamp
78	Added Section 17.15 – Vibration Mounts
77	Added Section 17.14 – Torque values for IGUS CFX Clamps
76	Table 30 – Heavy-Duty Hose Clamp (T-Bolt Style). Model number and torque values updated
75	Added Section 17.13 – Torque value for EV9 Flow Control Valve (HPN 7610661)
74	Added Section 17.8.1 – Torque value for Hydac Differential Pressure Transmitter (HPN 6404099). Torque values for orifices on hydraulic manifolds added (See Table 27). Torque values for gas valves added (See Section 17.12)
73	Updated torque for heater bands which have corrugated sheet metal on the outside diameter and also having an M6 clamping screw (Section 15, Table 22). Also updated torque values in section 17.7 for the Hydac oil level sight gauge to align with supplier specification.
72	Updated torque requirements for EOAT Tube Retainer Pins in section 19.2. Section 17.8 Torque values for Hydac PTs reviewed with Hydac (Feb. 16, 2022) and increased from 20 N-m to 40 N-m. The purpose of the increased torque is to reduce/eliminate oil leakage from PT and fitting interface. Both Hydac and Husky test results show insignificant effect of increased torque on PT performance (i.e. insignificant null point shift).
71	Added section 19.13: Torque Specification for NexPET Core Sleeve Set Screws. DLO specifications updated (2205)
70	Updated CoolPik Vacuum/Blow Pin Torque Specifications Table 40 with values for M20 blow pins

69	Removed Adhesive info and moved to HS 897 – Adhesive Standard. Left Torque/Loctite info for clamp fasteners.
68	Section 17.08 Torque values added for new Hydac PT HPN 9247632
67	Lubrication notes added to section 14 - Torque values for fittings (HGT-FT)
66	Section 14 Torque values for fittings (HGT-FT) reviewed and updated: Section 14.1 relocated and revised to clarify assembly lubrication practices. Tables 12, 13, 14, 15, 18 and 19 updated as per the latest industry standards from Parker and Manuli. Section 17.11 added: Torque value for male pressure test point specified as per latest Hydac catalog.
65	ORFS hose end fittings specifications: Increased torque values in table 13. Note: Previous torque values were too low especially for the smaller sizes and failed a pull test audit. Manuli torque values for nut tightening have been tested and approved. Warning: Husky torque specifications apply to lubricated parts while Manuli's apply in dry conditions. As a result, Husky exceeds Manuli's recommended preload.  DLO Details 2015 specifications: Sheet 1: Added Spade terminal "S0" and "S8" Code. Sheet 6: HPN 7404990 updated AWG and Torque value. HPN 5832899 updated AWG value. Sheet 8: Added * Larger termination screws Sheet 10: HPN 2172625 added load side termination details Sheet 11: Added HPN 2351717 Sheet 12: Added HPN 6344019 Sheet 14: Added HPN 8425223
64	DLO Details 1933 table updated to reflect current product usage along with torque value consolidation - See section 15 or DLO Details (English) 1937 or DLO Details (Chinese) 1937 specifications
63	DLO device torque specifications changes (DLO Details 1933) - See section 15 or <a href="#">HGT-EL DLO</a>
62	Unit changed from ft-lb to in-lb in Table 22 - HGT-EL Metric and Imperial Screws, Mounting Hardware (Electrical Applications) to align with other tables and tooling in use
61	HF and Cxx stopper code notes updated in <a href="#">HGT-EL DLO</a>
60	Section 17.6 Added value for 2.5" G2 Section 17.5 Updated table for DBDS relief valves
59	Added Section 17.10 for Numatics air valve assemblies
58	Section 17.8 updated. Old Hydac pressure transducer (HPN 3875996) replaced with new (HPN 7980938)
57	Added torques for Stopflex hose bands and heavy-duty hose clamp (T-Bolt style)
56	Added torque for electrical cabinet door ground stud
55	Updated as per SR 51455: Added note/picture for <u>Cold Half and Hot Runner Mounting to Machine Platen</u> in <u>Husky General Torque (HGT) - Standard Applications</u>
54	Updated as per SR 50799: Added sections 19.9, 19.10, 19.11, 19.12. Updated Sections 19.5, 19.6, 19.7, 19.9. Replaced and moved the table from section 19.7 to section 19.8
53	Added torque specifications for Premolded Cables, Electrical Applications). Bookmarks to multiple tables added. Table for HGT-35 specifications updated (Stainless steel A2, socket head cap screw application added)
52	Table for HGT-EL Heater Bands, Electrical Applications updated. Torque values for UNC # 1/4 - 20 spider straps and post terminal nut added. Torque values for Danfoss pressure transducers added (see section 17.9)
51	Added torque specifications for Neck Ring Plugs
50	Section 15 – HGT-EL Heater Bands, Electrical Applications updated. Torque value applied to ground stud nut specified.
49	Section 4 – References updated for HGT 80, 50 and 35 torque calculations (units of measure added)
48	Torque value for solid state relay added
47	2739013 CAM follower torque specifications updated

46	Table 1 updated and new Figure 1 added to clarify Husky General Torque Standard Applications (#1 to 8)
45	Torque values for Watlow heater bands added
44	Updated torque values for Watlow heater bands, torque values for Hydac oil level indicators added (see section 17.7), torque values for Hydac pressure transducers added (see section 17.8). HGT-EL DLO updated as per latest master
43	Updated torque values for HGT-LHCS (Low Head Cap Screws)
42	Section 19.1
41	Baumuller torque values in HGT-EL DLO updated to reflect mid-range torque values
40	Minor addition to sheet 6 in HGT-EL DLO as per manufacturing request
39	HGT-LHCS (Low Head Cap Screws) specifications added (section 13). Warning section added (section 5)
38	Section 13 updated (HGL-EL). Torque values for DLO related connections removed and consolidated into a separate document: HGT-EL DLO
37	Updated torque values for COOLPIK blow/vacuum pins in section 19.3 . Reference SIR 105554
36	Torque values for heater bands added/updated
35	Added note that states: “this document has a duplicate copy that’s published to <a href="http://www.husky.co">www.husky.co</a> , all future revisions must be posted to <a href="http://www.husky.ca">www.husky.ca</a> ”
34	Reference to Ampco 18 mounting screws removed
33	Added screw interchangeability notes in tables 4, 5, 6, and 8. Added screw interchangeability warning in section 5
32	Added new Section 17 for PET Mold and Hot Runner Special Torque Applications
31	Tables under section 15.8 reformatted (bladder accumulator neck adaptor specifications)
30	Torque values for accumulator neck adaptors added
29	Application notes (section 5.1) reviewed and updated: Torque values for high temperature applications (>150°C) statement clarified
28	HGT-EL torque values for Breakers, fuses and lugs updated
27	Baumuller BM44XX Servo Drive Torque values added
26	Torque values for SAE plugs reviewed and updated
25	CAM follower torque values have been in Section 15.7
24	Torque values added to HGT-EL Lugged Connections - Electrical Applications
23	Torque values for SAE plugs updated
22	Torque values for Siemens 5SY series breaker added
21	Torque values for Woehner and Ferraz Shawmut fuse holder added
20	Torques for Bosch Rexroth DBDS pressure relief valves added (see section 17.5)
19	Lubricants section removed (transferred to HS 609)
18	Section 7.1, gearbox oil added
17	Hoist ring torquing requirements updated (SR 13841)
16	Remove note in revision 15
15	Add note for 4mm socket option for M10 (see section 10, B note)
14	Updated ‘Table 1 – Husky General Torque Standards Applications’: HR and Mold Liftbars with M30 installations to use HGT-35 – SR13141
13	Updated ‘Table 1 – Husky General Torque Standards Applications’: HR Liftbars to use HGT-50 as well – SR13141
12	Torques for electrical components added. References to “Husky Classes” added (e.g. Unbrako, Holokrome, YFS, etc. socket head cap screws).
11	Added applications notes for adhesives usage and selection (section 7.2.1 and 7.2.2 added)
10	Table 1 and application notes (section 5.1) updated to clarify the default preload (HGT-80, 50 or 35). Drawing specifications section updated (see section 14). Torque table shown on assembly drawings replaced by a note referring to the HS 252.
9	Approved hydraulic oils specified in HS 207. Reference to HS207 added to “Lubricants for General Application” section (Table 2). Note: table 2 transferred to HS 609 (see revision 19)
8	Added Manuli hose fittings, torque tolerances changed to +/-4% (section 6 updated)

7	Torque values applied to threaded rod applications and maximum allowable preload on 10.9 fasteners
6	New torque chart for AMPCO 18 applications added (see section 15.5), FFWR torque values for ORFS fittings added
5	Section 4 references added, section 6 torque tolerances added, tolerance values reviewed by tool supplier, document title changed.
4	New standard template used, torque values for SAE plugs updated, bulkhead locknut torque values added, torque for BSPT fittings and plugs added, lubricant section modified, torque tolerances added, etc.
3	Torque values for grade 10.9 and 12.9 screws consolidated, torque values for hydraulic applications and split flanges added, drawing specifications section updated, etc.
2	New format, new part numbers for FGL-2 grease, updated notes and units of measure
1	Published to Site
0	Original Issue

## 1 SCOPE

HGT (Husky General Torque) is a general torque standard that applies to threaded connections that do not have their respective torque values indicated on the drawing. Any other torque values such as the supplier's recommended torque specifications specified in Section 17 or any other deviations from the general standard must be individually specified on the drawing. Any deviations from this standard must be justified by calculations.

## 2 PURPOSE

To provide a list of general torque values and lubrication practices to be used on Husky product.

## 3 DOCUMENT CONTROL

Revisions to this document shall be authorized by Corporate Operations.

## 4 REFERENCES

The torque values specified in this document come from the following Industry Standards, Suppliers Catalogs and/or formulae:

HGT-80 Metric Fasteners	$T = K \cdot F \cdot d$ - Torque T in Newton-meter - Coefficient of friction $\mu = 0.12$ - Torque coefficient K ( $0.15 \leq K \leq 0.17$ ) - Induced screw load F in Newton - Nominal diameter d in meter - ISO 898-1 (grades 12.9 & 10.9) and ASTM A574	Standard proofload ratios: 80, 50 and 35%. E.g. 80% preload means that the torque will produce enough energy to achieve 80% of what the bolt is capable of without permanent deformation.
HGT-80 Imperial Fasteners		
HGT-50 Metric Fasteners		
HGT-50 Imperial Fasteners		
HGT-35 Metric Fasteners		
HGT-35 Imperial Fasteners		
HGT-SS Metric Set Screws	ISO 898/5-1980 Table 5 and ASTM F912-1986 Table 2	
HGT-SS Imperial Screws	ASTM F912-1986	
HGT-LHCS Metric Screws	Torque values provided by manufacturer	
HGT-FT ORFS Tube Ends	Parker Catalog 4300 (April 2017)	
HGT-FT SAE and BSPP Ends	Parker Catalog 4300 (April 2017)	
HGT-FT ORFS Hose Ends	Manuli Hydraulics catalog 2020	
HGT-FT JIC Ends	Parker Catalog 4300 (April 2017)	
HGT-FT NPT and BSPT Plugs and Fittings	Parker Catalog 4300 (April 2017)	
HGT-FT Flareless Tube Ends	Parker Catalog 4300 (April 2017)	
HGT-FT SAE Plugs	Parker Catalog 4300 (April 2017)	
HGT-FT Bulkhead Locknuts	Parker Catalog 4300 (April 2017)	
HGT-FT BSPP Plugs	Former Luxembourg Machine torque standard (LTML111)	
HGT-FT Metric Plugs	Former Luxembourg Machine torque standard (LTML111)	
HGT-EL Metric and Imperial Screws	Electric Components Supplier	
Torque for Hydraulic Valves Mounting Bolts	Torque values provided by manufacturer	
Torque for Orifices on Hydraulic Manifolds	Former Luxembourg Machine torque standard (LTML111)	
Torque for Hose/Pipe Clamps Mounting Bolts	Former Luxembourg Machine torque standard (LTML111)	
Torques for Hydraulic Motors Mounting Bolts	Torque values provided by manufacturer	
Code 61 Split Flange Assemblies	ISO 6162-1994	
AMPCO 18 Applications	Torque values provided by manufacturer	
Code 62 Split Flange Assemblies	ISO 6162-1994	



## 5 WARNINGS

Always use the correct parts and the proper torques. Incorrect fastener connections can dangerously weaken assemblies. Ensure that all safety information, instructions and warnings such as shown in the two examples below are read and understood before any operation or any maintenance procedures are performed.

### CAUTION!

Mechanical hazard – risk of equipment damage. Use of improper torque can result in equipment damage. Consult the assembly drawings for the torque specifications before referring to the torque charts in this section.

### WARNING!

Molten plastic spray hazard - risk of serious injury and equipment damage. If incorrectly sized screws are used, equipment damage may occur that could result in uncontained molten plastic spray. If replacing the screws, only use the screw sizes specified in the machine bill of material.

## 6 APPLICATIONS

HGT consists of seven torque standards HGT-80, HGT-50, HGT-35, HGT-SS, HGT-LHCS, HGT-FT and HGT-EL as shown in Table 1. For mechanical applications, screws are torqued to the HGT-80, HGT-50, HGT-35 or HGT-LHCS standards. For electrical applications, screws and other components are torqued to the HGT-EL standard. Set screws are torqued to the HGT-SS standard and fittings to the HGT-FT standard. Deviations from Husky General Torque Standards for Special PET Mold and Hot Runner applications are listed below and are cited in detail in section 19.

- 19.1 CAM Follower Torque Specifications
- 19.2 EOAT Tube Retainer Pin Torque Specification
- 19.3 CoolPik Vacuum/Blow Pin Torque Specifications
- 19.4 CoolPik Moving Puck Installation Torque Specification
- 19.5 CoolPik Plate Mounting Torque Specification
- 19.6 Mold/Hot Runner Lift Bars Mounting Screws Torque Applications
- 19.7 Gib/Wear Plate Mounting Screws Torque Specification
- 19.8 Neck ring plugs Torque Specification
- 19.9 Stack Inserts Torque Specification
- 19.10 Torque Specification for Water Manifolds to Slides
- 19.11 Torque Specification for Slide to Connecting Bars
- 19.12 Torque Specification for EOAT Assy. to Robot
- 19.13 Torque Specification for NexPET Core Sleeve Set Screws

**Figure 1 – Husky General Torque (HGT) - Standard Applications (# 1 to 8)**

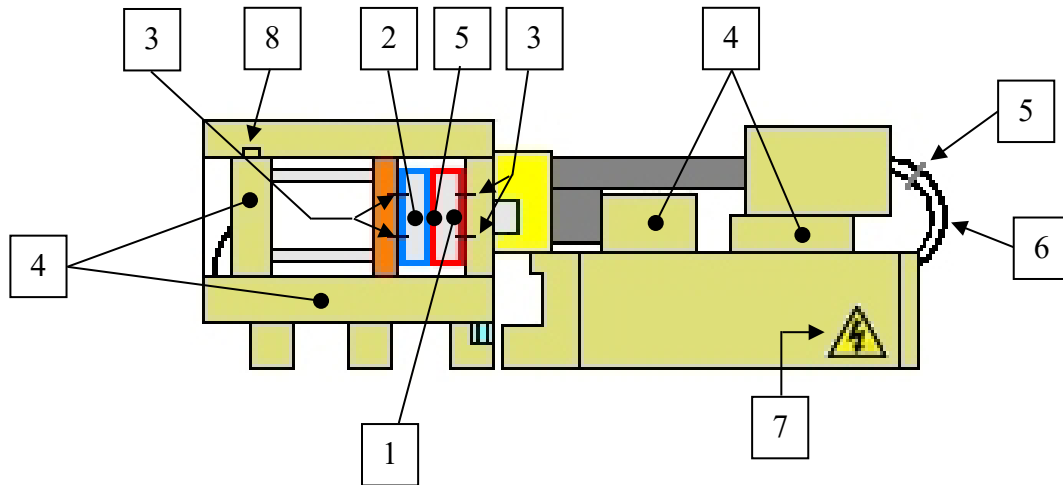

**Table 1 – Husky General Torque (HGT) - Standard Applications**

Application		Hardware		Base/Threaded Material	Torque Standard
Mechanical	Hot Runner Assemblies 1	Screws and Threaded Rods	- DIN 912-12.9 SHCS* - DURLOK-12.9-UNB HHS - DIN 976-12.9 ROD	Steel Cast Iron	HGT-80
		Set Screws	- ISO 898/5-45H - ASTM F912	N/A	HGT-SS
		Low Head Cap Screws	- DIN 7984	N/A	HGT-LHCS
	Cold Half Assemblies (including Cavity plate assembly) 2	Screws and Threaded Rods	- DIN 912-12.9 SHCS* - DURLOK-12.9-UNB HHS - DIN 933 & 931-10.9 HHCS - DIN 976-12.9&10.9 ROD	Steel Cast Iron	HGT-50
		Set Screws	- ISO 898/5-45H - ASTM F912	N/A	HGT-SS
		Low Head Cap Screws	- DIN 7984-10.9 LHCS	N/A	HGT-LHCS
	Cold Half and Hot Runner Mounting to Machine Platen 3	SHCS	- DIN 912-12.9 SHCS*	Cast Iron	HGT-50**

\* Referred to as “Husky Classes 1, 2, 3 & 4” in HS 258

\*\* When using hex tool adapter to access mold mounting screws, no de-rating of torque value is required - See Figure 2

/... Continuing on next page

Application		Hardware		Base/Threaded Material	Torque Standard
Mechanical	<b>Machine Assemblies</b> <div style="border: 1px solid black; width: 20px; height: 20px; text-align: center; margin: 5px auto;">4</div>	Screws and Threaded Rods	- DIN 912-12.9 SHCS* - DURLOK-12.9-UNB HHS - DIN 933 & 931-10.9 HHCS - DIN 976-12.9&10.9 ROD - ASTM A574 SHCS	Steel Cast Iron	HGT-50
		Set Screws	- ISO 898/5-45H - ASTM F912	N/A	HGT-SS
	<b>All Assemblies Using a Weaker Base Material</b> <div style="border: 1px solid black; width: 20px; height: 20px; text-align: center; margin: 5px auto;">5</div>	Screws and Threaded Rods	- DIN 912-12.9 SHCS* - DURLOK-12.9-UNB HHS - DIN 933 & 931-10.9 HHCS - DIN 976-12.9&10.9 ROD - DIN 7991-10.9 FHCS - ISO 7380-10.9 BHCS - ASTM A574 SHCS	Cast Aluminum, Aluminum Plate	HGT-35
<div style="border: 1px solid black; width: 20px; height: 20px; text-align: center; margin: 5px auto;">6</div>	<b>Hydraulic, Lubrication, Air and Water</b>	Hose and Tube Fittings	- O-ring face Seal - JIC (37° Flared) - NPT, BSPP, Bite - SAE Straight Thread	N/A	HGT-FT
<div style="border: 1px solid black; width: 20px; height: 20px; text-align: center; margin: 5px auto;">7</div>	<b>Electrical</b>	Screws and other components	- Steel, Al& Cu, Brass screws	N/A	HGT-EL
<div style="border: 1px solid black; width: 20px; height: 20px; text-align: center; margin: 5px auto;">8</div>	<b>Hoist Rings</b>	Screws	- As supplied with Hoist Ring	N/A	Follow Supplier recommendation

\* Referred to as “Husky Classes 1, 2, 3 & 4” in HS 258

**Figure 2 – Using Hex Tool Adapter to Access Mold Mounting Screws**

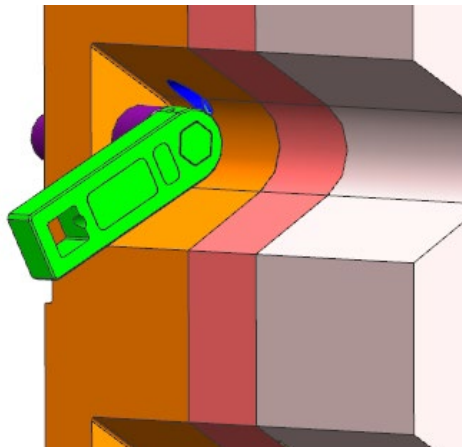

## 6.1 APPLICATION NOTES

- Washers are recommended for oversized holes and slots.
- Heavy washers (DIN 7349) are recommended for cast aluminum applications.
- The HGT-80 standard is recommended for the majority of Hot Runner products: These high strength and/or high fatigue applications use grade 12.9 bolts that will not crush, gall, warp or fracture the joint material under preload (e.g. high-strength alloy steel).
- The HGT-50 standard is recommended for the majority of Machine and Mold product applications. HGT-50 ensures that the area below the screw head does not bear into the seating material and the threads do not shear upon torquing.
- The HGT-35 standard is recommended for those applications where the yield strength of the base material would otherwise be exceeded under a 50% preload. An example is clamping a cantilevered section such as a belt clamp that is subject to bending stress.
- Torque values for high temperature applications (>150°C) should be calculated and individually specified on the drawing as required. If no values are indicated on the drawing, the general HGT standard should be used (e.g. HGT-50 for Machine and Mold applications, HGT-80 for Hot Runner applications).
- In all applications the joint must be designed to carry the load safely and without separation.
- Screw sizes and torque values must be supported by calculations for externally applied loads that are subjected to fatigue action such as pressurized vessels.
- When maintenance or service requires the replacement of screws, it is recommended that they be the same ones specified in the machine Bill of Material. Due to the interchangeability between some metric and imperial screws, incorrect sizes may provide insufficient bolt preload over time.

## 7 TORQUE TOLERANCES

The more accurate the method of controlling tightness the more of the strength of the fastener can be utilized. The tolerance values specified in this standard pertain to the tool's accuracy and not the induced fastener's load that is affected by other variables such as lubrication, clamped materials, temperature, etc. For example, assembly torque wrenches should be calibrated to stay within +/-4% when applying HGT-50, 80 or 35 and the fastener's induced load accuracy can be expected to range from +/- 10-20%.

## 8 LINK TO HS DOCUMENTS

HS 207 - Approved Hydraulic Fluids: Use products shown in table 1.

HS 609 - Lubricants and coolants: Use products shown in tables 1, 2 or 3 based on applications.

HS 897 - Adhesives: Use products shown in table 2 for soft joint applications.

## 9 HGT-80 STANDARD (SCREWS AND THREADED RODS - 80% PRELOAD)

The following torques must be applied to screws in order to produce the desired 80% preload.

**Table 2 – HGT-80 Metric Fasteners**

Grade 12.9 Fasteners			
Socket Head Cap Screw* (DIN912)			
Durlock Hex Head Cap Screw (UNB 12.9)			
Threaded Rod (DIN976)			
Size	Torque (+/- 4%)		Induced Screw Load (N)
	N-m	ft-lb	
M4	4.6	3.4	6800
M5	9.5	7.1	11000
M6	16	12	15600
M8	39	29	28400
M10	77	57	45000
M12	135	100	65000
M14	215	160	90000
M16	330	245	122000
M20	650	480	190000
M24	1100	810	273000
M30	2250	1660	435000
M36	3850	2840	634000
M42	6270	4630	870000
M48	8560	6320	1140000

**Table 3 – HGT-80 Imperial Fasteners**

ASTM A574 Fasteners			
Imperial Socket Head Cap Screw			
Size	Torque (+/- 4%)		Induced Screw Load (N)
	N-m	ft-lb	
#8	5	4	7000
#10	7	5	8700
1/4	16	12	15800
5/16	35	25	26100
3/8**	60	45	38000
7/16**	95	70	53000
1/2	150	110	71000
5/8	290	210	108000
3/4**	500	360	160000
7/8	790	580	222000
1	1180	865	291000
1 1/8	1680	1240	367000
1 1/4	2400	1750	466000
1 3/8	3100	2300	555000
1 1/2	4100	3040	676000
1 3/4	6500	4800	911000

\* Referred to as “Husky Classes 1, 2, 3, and 4” in HS 258.

\*\* When maintenance or service requires the replacement of screws, it is recommended that they be the same ones specified in the machine Bill of Material. Due to the interchangeability between some metric and imperial screws, incorrect sizes may provide insufficient bolt preload over time.

## 10 HGT-50 STANDARD (SCREWS AND THREADED RODS - 50% PRELOAD)

The following torques must be applied to screws in order to produce the desired 50% preload.

**Table 4 – HGT-50 Metric Fasteners**

Grade 12.9 and 10.9 Fasteners			
Socket Head Cap Screw* (DIN912)			
Hex Head Cap Screw (UNB 12.9, DIN933, DIN931)			
Threaded Rod (DIN976)			
Size	Torque (+/- 4%)		Induced Screw Load (N)
	N-m	ft-lb	
M4	3	2.2	4250
M5	6.2	4.6	8900
M6	10	7	9800
M8	25	18	17800
M10	53	40	31500
M12	95	70	47000
M14	130	95	56000
M16	220	160	85000
M18**	270	200	93000
M20	390	290	124000
M24	660	490	171000
M30	1300	960	272000
M36	2300	1700	396000
M42	3700	2700	544000
M48	5500	4000	714000

**Table 5 – HGT-50 Imperial Fasteners**

ASTM A574 Fasteners			
Imperial Socket Head Cap Screw			
Size	Torque (+/- 4%)		Induced Screw Load (N)
	N-m	ft-lb	
#8	3	2	4360
#10	4	3	5450
1/4	11	8	9900
5/16	22	16	16300
3/8**	40	30	24000
7/16**	60	45	33000
1/2	95	70	44000
5/8	180	135	68000
3/4**	310	230	100000
7/8	490	360	139000
1	750	550	182000
1 1/8	1040	770	230000
1 1/4	1480	1090	291000
1 3/8	1940	1430	347000
1 1/2	2580	1900	423000
1 3/4	4050	2990	570000

\* Referred to as “Husky Classes 1, 2, 3, and 4” in HS 258.

\*\* When maintenance or service requires the replacement of screws, it is recommended that they be the same ones specified in the machine Bill of Material. Due to the interchangeability between some metric and imperial screws, incorrect sizes may provide insufficient bolt preload over time.

## 11 HGT-35 STANDARD (SCREWS - 35% PRELOAD)

The following torques must be applied to screws in order to produce the desired 35% preload.

**Table 6 – HGT-35 Metric Fasteners**

Grade 12.9, 10.9 and A2 Fasteners			
Socket Head Cap Screw* (DIN912)			
Socket Head Cap Screw*** (Stainless Steel, A2)			
Hex Head Cap Screw (UNB 12.9, DIN933, DIN931)			
Flat Head Cap Screw (DIN7991)			
Button Head Cap Screw (ISO7380)			
Size	Torque (+/- 4%)		Induced Screw Load (N)
	N-m	ft-lb	
M4	2.1	1.5	2980
M5	4	3	4800
M6	9	7	7800
M8	19	14	14200
M10	37	27	22000
M12	50	37	24500
M16	125	90	49000
M20	250	185	79000
M24	440	325	115000
M30	875	650	182000
M36	1530	1130	265000

**Table 7 – HGT-35 Imperial Fasteners**

ASTM A574 Fasteners			
Imperial Socket Head Cap Screw			
Size	Torque (+/- 4%)		Induced Screw Load (N)
	N-m	ft-lb	
#8	1	1	2670
#10	3	2	3100
1/4	7	5	5800
5/16	14	10	9800
3/8**	23	17	14200
7/16**	38	28	20000
1/2	58	42	26700
5/8	110	81	41000
3/4**	180	135	60000
7/8	300	220	83000
1	450	330	111000
1 1/8	620	460	138000
1 1/4	890	660	175000
1 3/8	1170	860	208000
1 1/2	1550	1140	254000
1 3/4	2450	1790	342000

\* Referred to as “Husky Classes 1, 2, 3, and 4” in HS 258.

\*\* When maintenance or service requires the replacement of screws, it is recommended that they be the same ones specified in the machine Bill of Material. Due to the interchangeability between some metric and imperial screws, incorrect sizes may provide insufficient bolt preload over time.

\*\*\* HGT-35 is the proper torque for stainless steel screws (strength of stainless steel screw is 70% of grade 10.9).

## 12 HGT-SS STANDARD (SET SCREWS)

The following torques must be applied to set screws.

**Table 8 – HGT-SS Metric Set Screws**

ISO 898/5-45H Set Screws Metric Socket Set Screw (DIN913-14-15-16)		
Size	Torque (+/- 4%)	
	N-m	ft-lb
M3	0.9	0.66
M4	2.2	1.6
M5	4	3
M6	7.2	5.3
M8	17	12.6
M10	33	24
M12	54	40
M16	134	99
M20	237	175
M24	440	325

**Table 9 – HGT-SS Imperial Screws**

ASTM F912 Set Screws Imperial Socket Set Screw ANSI B18.3.1)		
Size	Torque (+/- 4%)	
	N-m	ft-lb
#5	1.1	0.8
#6	1.1	0.8
#8	2.7	2
#10	4	3
1/4	9.5	7
5/16	19	14
3/8	33	24
1/2	70	52
9/16	70	52
5/8	150	110
3/4	270	200
7/8	410	300
1	570	420



## 13 HGT-LHCS STANDARD (LOW HEAD CAP SCREWS)

The following torques must be applied to low head cap screws.

**Table 10 – HGT-LHCS Metric Low Head Cap Screws**

Grade 10.9 Low Head Cap Screws Low Head Cap Screws (DIN 7984)		
Size	Torque (+/- 4%)	
	N-m	in-lb
M4	2.7	24
M5	5.4	48
M6	9.15	81
M8	22	195
M10	44	389
M12	77	682
M16	190	1681
M20	371	3284

## 14 HGT-FT STANDARD (FITTINGS)

The following tables provide the recommended torque values required for the safe and effective operation of the fittings using a torque wrench or other methods such as “Turn From Finger Tight”, “Flats From Finger Tight” or “Flats from Wrench Resistance”. For TFFT or FFFT, the joint should be hand tightened snugly and then tightened with a wrench by the number of flats or turns indicated by the table. For “FFWR”, the joint should be tightened snugly with a wrench and then tightened again with the same wrench by the number of flats indicated by the table. The torque method of assembly is the preferred method of assembly. It reduces the risk of human error during assembly that is more prevalent in the “FFWR” method. To ensure the most accurate assembly of the fitting, it is strongly recommended that the torque method be utilized.

### 14.1 IMPORTANT NOTES

- O-rings must always be lubricated.
- Refer to the notes in red and the following symbols to determine if lubricant should be applied to threads.



Apply lubricant to threads



Do not apply lubricant to threads

- Values are for steel fittings in steel ports.
- For stainless steel fittings, please use the upper limit of torque range. Exclusion: NPT and BSPT fittings.
- For brass, aluminum (and other soft metals), decrease torque value by 35%. Exclusion: NPT and BSPT fittings.
- For NPT and BSPT elbows, never back off to achieve alignment.
- For ferrule (bite) fittings, manually screw the nut on the fitting body until finger tight. Continue to tighten the joint with a wrench by the number of flats indicated in the table. If the fitting body was used for ferrule pre-set, the nut must be re-tightened to the same fitting body used earlier in pre-set.
- Assembled parts (nut and adapter) must have identical plating.
- Torque values shown apply to the ends indicated by arrows.

**Table 11 – HGT-FT ORFS Tube Ends**

O-ring Face Seal Tube Ends				
				
SAE Dash Size	Thread Size Inch	Tube Side Torque * (+10% - 0) Nm (ft-lb)	FFWR Tube Nuts (min-max)	FFWR Swivel & Hose Ends (min-max)
-4	9/16 - 18	25 (18)	1/4 - 1/2	1/2 - 3/4
-6	11/16 - 16	40 (30)	1/4 - 1/2	1/2 - 3/4
-8	13/16 - 16	55 (40)	1/4 - 1/2	1/2 - 3/4
-10	1 -14	80 (60)	1/4 - 1/2	1/2 - 3/4
-12	1-3/16 - 12	115 (85)	1/4 - 1/2	1/3 - 1/2
-16	1-7/16 - 12	150 (110)	1/4 - 1/2	1/3 - 1/2
-20	1-11/16 - 12	205 (150)	1/4 - 1/2	1/3 - 1/2
-24	2 - 12	315 (230)	1/4 - 1/2	1/3 - 1/2
-32	2 1/2 -12	510 (375)	1/4 - 1/2	1/3 - 1/2

**\* IMPORTANT: Recommended torques values are only applicable for nut tightening in dry conditions (no oil or lubrication on threads and sealing surfaces, only O-rings must be lubricated). For brass, aluminum (and other soft metals), decrease torque value by 35%. However, FFWR is the same.**



**Table 12 – HGT-FT ORFS Hose Ends (Manuli Hose Fittings)**

O-ring Face Seal						
						
SAE Dash Size	Hose ID	Thread Size	Recommended Torque *		Rotation Angle (degrees)	FFFT Hose Ends
			Nm (0, +10%)	ft-lbs (0, +10%)		
-4	1/4"	9/16"-18	26	19	45°	3/4
-6	3/8"	11/16"-16	42	31	45°	3/4
-8	1/2"	13/16"-16	57	42	60°	3/4
-10	5/8"	1"-14	85	63	45°	1
-12	3/4"	1 3/16"-12	122	90	45°	3/4
-16	1"	1 7/16"-12	156	115	45°	3/4
-20	1 1/4"	1 11/16"-12	200	148	45°	3/4
-24	1 1/2"	2"-12	256	189	45°	3/4

**\* IMPORTANT: Recommended torques values are only applicable for nut tightening in dry conditions (no oil or lubrication on threads and sealing surfaces, only O-rings must be lubricated).**

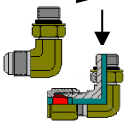
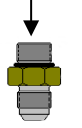
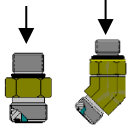

**Table 13 – HGT-FT SAE and BSPP Ends**

Adjustable and Non-Adjustable SAE and BSPP Ends (Plugs excluded)				
SAE Dash Size	Thread Size Inch	Torque * (+10% - 0)		
		JIC, Ferrule Fittings	JIC, Ferrule & Pipe Fittings	Face Seal Fittings
		Adjustable 	Non-Adjustable 	Adjustable and Non-Adjustable 
		Nm (ft-lb)	Nm (ft-lb)	Nm (ft-lb)
-4	7/16 - 20	20 (15)	29 (15)	20 (15)
-6	9/16 - 18	40 (30)	40 (30)	46 (35)
-8	3/4 - 16	70 (52)	70 (52)	80 (60)
-10	7/8 - 14	115 (85)	115 (85)	135 (100)
-12	1-1/16 - 12	185 (135)	185 (135)	185 (135)
-14	1-3/16 - 12	235 (175)	235 (175)	235 (175)
-16	1-5/16 - 12	270 (200)	270 (200)	270 (200)
-20	1-5/8 - 12	340 (250)	340 (250)	340 (250)
-24	1-7/8 - 12	415 (305)	415 (305)	415 (305)
-32	2-1/2 - 12	510 (375)	510 (375)	510 (375)

**\* IMPORTANT: Lubricate threads before assembly. Values in chart are for plated steel fittings in steel ports. For stainless steel fittings, use the upper limit of torque range. For brass and aluminum, decrease torque value by 35%.**

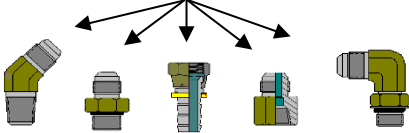

**Table 14 – HGT-FT JIC Ends**

JIC (37 Deg Flared Tube) Ends				
				
SAE Dash Size	Thread Size Inch	Assembly Torque * (+10% - 0) Nm (ft-lb)	Tube End FFWR	Hose End or Swivel Nut FFWR
4	7/16 - 20	18 (13)	2 1/2	2
6	9/16 - 18	30 (22)	2	1 1/2
8	3/4 - 16	57 (42)	2	1 1/2
10	7/8 - 14	81 (60)	1 1/2	1 1/2
12	1-1/16 - 12	115 (84)	1 1/2	1 1/4
14	1-3/16 - 12	135 (100)	1 1/2	1 1/4
16	1-5/16 - 12	160 (118)	1 1/2	1
20	1-5/8 - 12	230 (168)	1	1
24	1-7/8 - 12	265 (195)	1	1
32	2-1/2 - 12	360 (265)	1	1
40	3-12	Not Applicable	1	1

**\* IMPORTANT: Torque values are for unlubricated carbon steel components and properly lubricated stainless-steel components.**



**Table 15 – HGT-FT NPT and BSPT Plugs and Fittings**

NPT and BSPT Fittings and Plugs		
Torque *		
NPTF Inch	BSPT Inch	TFFT (min-max)
1/8-27	1/8-28	2 - 3
1/4-18	1/4-19	2 - 3
3/8-18	3/8-19	2 - 3
1/2-14	1/2-14	2 - 3
3/4-14	3/4-14	2 - 3
1 - 11-1/2	1 - 11	1.5 - 2.5
1-1/4 - 11-1/2	1-1/4 - 11	1.5 - 2.5
1-1/2 - 11-1/2	1-1/2 - 11	1.5 - 2.5
2 - 11-1/2	2 - 11	1.5 - 2.5

**\* IMPORTANT:**  
Carbon & stainless steel components:  
Apply lubricant to male pipe threads if not pre-applied. The first to two threads should be left uncovered to avoid system contamination.



**Table 16 – HGT-FT Flareless Tube Ends**

Ferrule (Bite) Fittings		
Torque *		
SAE Dash Size	Thread Size Inch	Nut TFFT (min-max)
4	7/16 - 20	1/6 - 1/4
6	9/16 - 18	1/6 - 1/4
8	3/4 - 16	1/6 - 1/4
10	7/8 - 14	1/6 - 1/4
12	1-1/16 - 12	1/6 - 1/4
14	1-3/16 - 12	1/6 - 1/4
16	1-5/16 - 12	1/6 - 1/4
20	1-5/8 - 12	1/6 - 1/4
24	1-7/8 - 12	1/6 - 1/4
32	2-1/2 - 12	1/6 - 1/4

**\* IMPORTANT:**  
Carbon steel components:  
Lubricate threads before assembly. No additional lubrication is required for stainless steel fittings as the nuts are pre-lubricated.



**Note:** For final assembly of swivel nut fittings (R6BU, C6BU and S6BU), a 3/4 TFFT is required for all sizes.

**Table 17 – HGT-FT SAE Plugs**

SAE Straight Thread Plugs			
SAE Dash Size	Thread Size	Torque * (+10% - 0)	
		Hollow Hex Plug	Hex Plug
	Inch	Nm (ft-lb)	Nm (ft-lb)
-2	5/16 - 24	7 (5.2)	10 (7.4)
-3	3/8 - 24	11 (8.1)	18 (13)
-4	7/16 - 20	20 (14.8)	29 (21)
-5	1/2 - 20	28 (20.7)	32 (23)
-6	9/16 - 18	40 (30)	40 (30)
-8	3/4 - 16	70 (52)	70 (52)
-10	7/8 - 14	115 (85)	115 (85)
-12	1-1/16 - 12	185 (135)	185 (135)
-14	1-3/16 - 12	235 (175)	235 (175)
-16	1-5/16 - 12	270 (200)	270 (200)
-20	1-5/8 - 12	340 (250)	340 (250)
-24	1-7/8 - 12	415 (305)	415 (305)
-32	2-1/2 - 12	510 (375)	510 (375)

**\* IMPORTANT:**  
Lubricate threads before assembly.



**Table 18 – HGT-FT Bulkhead Locknuts**

Bulkhead Locknuts		
SAE Dash Size	Torque * (+10% - 0)	
	O-ring Face Seal Ends	JIC or ferrule Ends
	Nm (ft-lb)	Nm (ft-lb)
4	20 (15)	18 (13)
6	34 (25)	35 (25)
8	75 (55)	65 (50)
10	115 (75)	115 (85)
12	180 (125)	180 (135)
14	230 (170)	230 (170)
16	270 (200)	270 (200)
20	330 (245)	330 (245)
24	365 (270)	365 (270)
32	Not Applicable	420 (310)

**\* IMPORTANT:**  
Torque values are only applicable for nut tightening in dry conditions



**Table 19 – HGT-FT BSPP Plugs**

BSPP Plugs	
Thread Size	Torque * (+10% - 0)
	
Inch	Nm (ft-lb)
1/8 - 28	13 (9.6)
1/4 - 19	30 (22)
3/8 - 19	60 (44)
1/2 - 14	80 (60)
3/4 - 14	140 (105)
1 - 11	200 (155)
1-1/4 - 11	400 (295)
1-1/2 - 11	450 (330)

**\* IMPORTANT:  
Lubricate threads  
before assembly**



**Table 20 – HGT-FT Metric Plugs**

Metric Plugs	
Thread Size	Torque * (+10% - 0)
	
Metric	Nm (ft-lb)
M42	400 (295)
M48	500 (370)
M52	600 (440)
M60	800 (590)
M64	850 (630)
M68	1000 (740)
M70	1100 (810)
M75	1300 (960)
M80	1550 (1150)
M85	1800 (1330)
M90	2000 (1480)

**\* IMPORTANT:  
Lubricate threads  
before assembly**



## 15 HGT-EL STANDARD (ELECTRICAL APPLICATIONS)

The following torque values should be used in the case of electrical applications. Notes: For non-standard components, use the recommended manufacturer's specifications. For DLO (Diesel Locomotive Cable) related connections, please call Husky Service or refer to section 20.1 - DLO Device Details.

**Table 21 – HGT-EL Metric and Imperial Screws, Mounting Hardware (Electrical Applications)**

Metric and Imperial Screws				
Size		Torque Nm (in-lb) (+10% - 0)		
		Steel	Al & Cu	Brass
M3	#4	0.7 (6.2)	0.3 (2.6)	0.6 (5.3)
M3.5	#6	1 (8.8)	0.5 (4.4)	0.8 (7.1)
M4	#8	1.3 (11.5)	0.7 (6.2)	1.2 (10.6)
M5	#10	1.9 (16.8)	1 (8.8)	1.7 (15.0)
M6	1/4	6 (53.1)	3 (26.5)	5 (44.2)
M8	5/16	8 (70.8)	4 (35.4)	5 (44.2)
M10	3/8	10 (88.5)	5 (44.2)	8 (70.8)

**Table 22 – HGT-EL Heater Bands (Electrical Applications)**

Heater Band Fasteners				
Fastener Size	Fastener Type			
	Nickel or Zinc Plated Dry	Nickel or Zinc Plated Anti-Seize	Black Oxide Dry	Black Oxide Anti-Seize
UNC # 6 - 32	30 lb-in / 3.4 N-m	20 lb-in / 2.3 N-m	20 lb-in / 2.3 N-m	15 lb-in / 1.7 N-m
UNC # 8 - 32	40 lb-in / 4.5 N-m	30 lb-in / 3.4 N-m	25 lb-in / 2.8 N-m	20 lb-in / 2.3 N-m
UNC # 10 - 24	55 lb-in / 6.2 N-m	35 lb-in / 4.0 N-m	35 lb-in / 4.0 N-m	30 lb-in / 3.4 N-m
UNC # 1/4 - 20	80 lb-in / 9.0 N-m	55 lb-in / 6.2 N-m	50 lb-in / 5.6 N-m	45 lb-in / 5.1 N-m
UNC # 1/4 - 20 Barrel Bar Clamp* and Spider Straps	80 lb-in / 9.0 N-m	80 lb-in / 9.0 N-m	80 lb-in / 9.0 N-m	80 lb-in / 9.0 N-m
UNC # 5/16 - 18	80 lb-in / 9.0 N-m	80 lb-in / 9.0 N-m	80 lb-in / 9.0 N-m	80 lb-in / 9.0 N-m
M6***	80 lb-in / 9.0 N-m	55 lb-in / 6.2 N-m	N/A	N/A

Heater Band Ground Stud Nut **	18 lb-in / 2.0 N-m maximum
Post Terminal Nut **	24 lb-in / 2.7 N-m maximum

\* For screws attached to each other through a 'common' barrel bar clamp

\*\* Use an open ended wrench to hold the nut closest to the heater as the wiring nut is torqued (threaded ground stud must not rotate).

\*\*\* For heater bands with corrugated sheet metal on outside diameter

**Table 23 – HGT-EL Solid State Relays (Electrical Applications)**

Solid state relays (e.g. HPN 231452, Crydom model# H12D4840DE 40A Dual SSR)	15 to 20 lb-in / 1.7 to 2.2 N-m
---	---------------------------------

**Table 24 – HGT-EL Premolded Cables (Electrical Applications)**

Premolded Cable Size	Torque
M8	3.5 lb-in / 0.4 N-m
M12	5.5 lb-in / 0.6 N-m

**Table 25 – HGT-EL Electrical Cabinet Door Ground Stud (Electrical Applications)**

M6	35 lb-in / 4.0 N-m
----	--------------------

## 16 DRAWING SPECIFICATIONS

- All fasteners and fittings requiring a torque value that deviates from the HGT standards or special torque specifications displayed in section 17 must be individually specified on the drawing next to the item reference (balloon or arrow on the assembly drawing as shown in Figure 3).
- A note referring to the torque standard (HS 252) will be inscribed in the title block of the assembly drawing (see in Figure 4).

**Figure 3 – Individual Torque Specifications**

Nm	155	lb-ft	115
----	-----	-------	-----

SIZE	QTY	Nm	lb-ft
M16	8	155	115
M20	8	325	240

UNIT	MC	SIZE	QTY	Nm	lb-ft
E85/E100	32	M16	8	155	115
E100/E120	38	M20	8	325	240



**Figure 4 – Husky General Torque Chart**

<p>FOR TORQUE SPECIFICATIONS, REFER TO HS 252</p>	<p>METRIC </p> <p>THIS DRAWING AND INFORMATION CONTAINED WITHIN IS CONFIDENTIAL AND/OR PROPRIETARY TO HUSKY INJECTION MOLDING SYSTEMS LTD. OR ONE OF ITS SUBSIDIARIES ("HUSKY") AND MAY NOT BE COPIED, DISCLOSED OR USED, IN WHOLE OR IN PART, WITHOUT THE PRIOR WRITTEN CONSENT OF HUSKY.</p>
<p>WEIGHT</p> <p>- kg</p>	<p>NO INTELLECTUAL PROPERTY RIGHTS ARE GRANTED INCLUDING ANY LICENSE IMPLIED OR OTHERWISE.</p> <p>ALL RIGHTS RESERVED. COPYRIGHT 2004 HUSKY.</p>

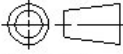
## 17 SUPPLIER RECOMMENDED TORQUE SPECIFICATIONS

The following torque values are recommended by suppliers and must be followed unless otherwise specified on the drawing.

### 17.1 HYDRAULIC MANIFOLDS – TORQUE VALUES FOR SCREWS

**Table 26 – Torque for Hydraulic Valves Mounting Bolts**

Torque N-m (ft-lb) Min.-Max.										
Bolt Size	Bosh			Rexroth			Moog/Hydrolux			Hyd. Option Segment Manifold
	Prop. Valves	Direct Valves	Cartridges	Prop. Valves	Direct Valves	Cartridges	Prop. Valves	Direct Valves	Cartridges	
M5	6-8 (4.4-5.9)	6-8 (4.4-5.9)		6.2-8.9 (4.6-6.6)	6.2-8.9 (4.6-6.6)		5.8-7.8 (4.2-5.7)	7.2-8 (5.3-5.9)		8.9-9.8 (6.6-7.2)
M6	11-14 (8.1-10.3)	11-14 (8.1-10.3)		11-15.5 (8.1-11.4)	11-15.5 (8.1-11.4)		9.4-12.6 (6.9-9.3)	11.7-13 (8.6-9.6)		15.5-17 (11.5-12.6)
M8			26-31 (19-23)			23-32 (17-23)			27-30 (20-22)	32-35 (23-26)
M10	40-50 (30-37)	50-60 (37-44)		53-75 (39-55)	53-75 (39-55)		46-62 (34-45)	50-55 (37-40)		75-83 (55-61)
M12	90-120 (66-88)	85-100 (63-73)	90-105 (66-77)	91-130 (67-96)	91-130 (67-96)	77-110 (57-81)	80-108 (59-80)	90-100 (66-74)	90-100 (66-74)	110-121 (81-89)
M16			240-260 (178-192)			189-270 (139-199)			270-300 (199-221)	270-297 (200-219)
M20	450-560 (332-410)		450-500 (332-369)	301-430 (222-317)	301-430 (222-317)	364-520 (268-383)	391-529 (288-390)	495-550 (365-406)	495-550 (365-405)	520-572 (385-422)
M24						630-900 (464-664)			810-900 (598-664)	900-990 (665-730)
M30						1260-1800 (929-1327)			1620-1800 (1195-1328)	1800-1980 (1330-1460)
Lubricant	Hydraulic Oil									Grease

Note: Those values are mandatory, regardless of screw quality used.

### 17.2 HYDRAULIC MANIFOLDS – TORQUE VALUES FOR ORIFICES

**Table 27 – Torque for Orifices on Hydraulic Manifolds**

Hydraulic Manifolds – Orifices		
Bolt Size	Torque (+/- 4%)	
	N-m	ft-lb
M5	4	3
M6	6	4.5
M8	13.5	10
M10	27	20
M12	47	35
M16	110	80
M20	195	145
M24	330	245
M30	650	480
Lubricant	Grease	

### 17.3 HOSE/PIPE CLAMPS – TORQUE VALUES FOR SCREWS

**Table 28 – Torque for Stauff or Hydac Hose/Pipe Clamps Mounting Bolts**

Clamp Type	Lubricant	Bolt Size	Clamp Size	Torque in Nm (ft-lb) (+/- 4%) with Clamping Material		
				Aluminum (AL)	Polypropylene (PP)	Polyamid (PA)
Single clamp Light series	Loctite	M6	0 to 6	12 (9)	8 (5.9)	10 (7.4)
Single clamp Heavy series		M10	1	30 (22)	12 (9)	20 (15)
			2	30 (22)	12 (9)	20 (15)
			3	35 (26)	15 (11)	25 (18)
		M12	4	55 (40)	30 (22)	40 (30)
		M16	5	120 (90)	45 (33)	55 (40)
		M20	6	220 (160)	80 (60)	150 (110)
Twin clamp		M6	1	N/A	5 (3.7)	6 (4.4)
			2	N/A	12 (8.9)	12 (8.9)
			3	N/A		
		M8	4	N/A	8 (5.9)	8 (5.9)
			5	N/A		

**Table 29 – Torque for Stopflex Hose Bands Mounting Bolts**

Stopflex Hose Bands				
				
Hose Band	Hose Outside Diameter (mm)		Bolt Size (metric)	Bolt Tightening Torque
Model Number	Ø MIN	Ø MAX	Ø M	Nm (ft-lb) (+/- 4%)
STOPFA13135	13	13.5	M6	3 (2)
STOPFA1415	14	15	M6	3 (2)
STOPFA1718	17	18	M6	3 (2)
STOPFA1819	18	19	M6	3 (2)
STOPFA2122	21	22	M6	3 (2)
STOPFA3031	30	31	M6	7 (5)
STOPFA3233	32	33	M6	7 (5)
STOPFA3839	38	39	M6	7 (5)
STOPFA3940	39	40	M6	7 (5)
STOPFA4547	45	47	M8	10 (7)
STOPFA5354	53	54	M8	10 (7)
STOPFA5456	54	56	M8	10 (7)
STOPFA5759	57	59	M8	10 (7)
STOPFA6668	66	68	M8	10 (7)
STOPFA7274	72	74	M8	10 (7)

**Table 30 – Heavy-Duty Hose Clamp (T-Bolt Style)**

King Seal Fastener Technology Part # KTB425 (100-108mm) HPN 10534088	50-60 in-lb (5.6-6.8 N-m)	
--	------------------------------	--

**Table 31 – Torque for Diffuser Hose Clamp**

Mikalor Steel Clamp Part # MIK-149-161 (6"ID Duct) HPN 2981775	26 ft-lb (35.3 N-m)	
--	------------------------	--

## ***17.4 HYDRAULIC MOTORS – TORQUE FOR MOUNTING BOLTS***

**Table 32 – Torques for Hydraulic Motors Mounting Bolts**

Torque N-m (ft-lb) +/-tolerance value	
Bolt Size	Hagglungs Hydraulic Motors
M16	280 +/-15 (205 +/-11)
M20	540 +/-20 (400 +/-15)
M24	900 +/- 30 (665 +/-22)
Lubricant	Hydraulic Oil

## ***17.5 BOSCH REXROTH DBDS PRESSURE RELIEF VALVES***

**Table 33 – Bosh Rexroth DBDS Pressure Relief Valves**

Size	Maximum Tightening Torque * (+/- 5%)	
	N-m	ft-lb
NG		
6	80	59
10	150	110
20	300	221
30	500	369

\* The tightening torques are recommended values assuming a friction coefficient of 0.12 and the use of a torque wrench.

## 17.6 BLADDER ACCUMULATOR NECK ADAPTOR SPECIFICATIONS

Table 34 – Bladder Accumulator Neck Adaptor Specifications

Accumulator Size	Accumulator Port Size	Torque [N-m]	Torque [ft-lb]
10L	BSPP 2" (G 2")	339 N-m	250 ft-lb
20L	BSPP 2" (G 2")	339 N-m	250 ft-lb
32L	BSPP 2" (G 2")	339 N-m	250 ft-lb
50L/54L	BSPP 2" (G 2")	339 N-m	250 ft-lb
50L High Flow	BSPP 2 1/2" (G 2 1/2")	420 N-m	310 ft-lb

## 17.7 HYDAC OIL LEVEL SIGHT GAUGE

HPN 2841146 (Hydac Model # 3070285 FSK127-2.5/0/-/12)  HPN 7604852 (Hydac Model # 3532906 FSKV-176-1.0/W/-/12 2SP)	M12 banjo bolts	Lubricated bolt: 6 N-m (+0.5, 0) 4.4 ft-lb (+0.4, 0)  Dry bolt: 8 N-m (0, -0.5) 5.9 ft-lb (, -0.4)
--	-----------------	--

## 17.8 HYDAC PRESSURE TRANSDUCERS

HPN 7980938 (Hydac Model # 926910 Pressure transmitter HDA 4776-A-300-453)	40 N-m (+10%, -0)	30 ft-lb (+10%, -0)
HPN 9247632 (Hydac Model # 927321 Pressure transmitter HPT 1776-A-0300-453)	40 N-m (+10%, -0)	30 ft-lb (+10%, -0)

### 17.8.1 HYDAC DIFFERENTIAL PRESSURE TRANSMITTER

HPN 6404099 (Hydac PN # 924030 Differential Pressure Transmitter HDT 5416-C-05.0-S-000, G1/2)	100 N-m (+10%, -0)	74 ft-lb (+10%, -0)
---	-----------------------	------------------------

## 17.9 DANFOSS PRESSURE TRANSDUCER

HPN 6830141 Danfoss Part # 063G2021, MBS 1250, 300 bar	M12x1	33 ft-lb (45 N-m) (+10%, -0)
---	-------	---------------------------------

## 17.10 NUMATICS AIR VALVE ASSEMBLY TORQUE SPECIFICATIONS

The following torque specifications are recommended by the supplier and should be used unless otherwise specified. These specifications apply to Numatics 2012, 2035, ISO 1, ISO 2 & ISO 3 air valve assemblies.

### 17.10.1 TORQUE SPECIFICATIONS FOR NUMATICS 2012 & 2035 AIR VALVE ASSEMBLIES

Figure 5 – Numatics 2012 & 2035 Air Valve Assemblies

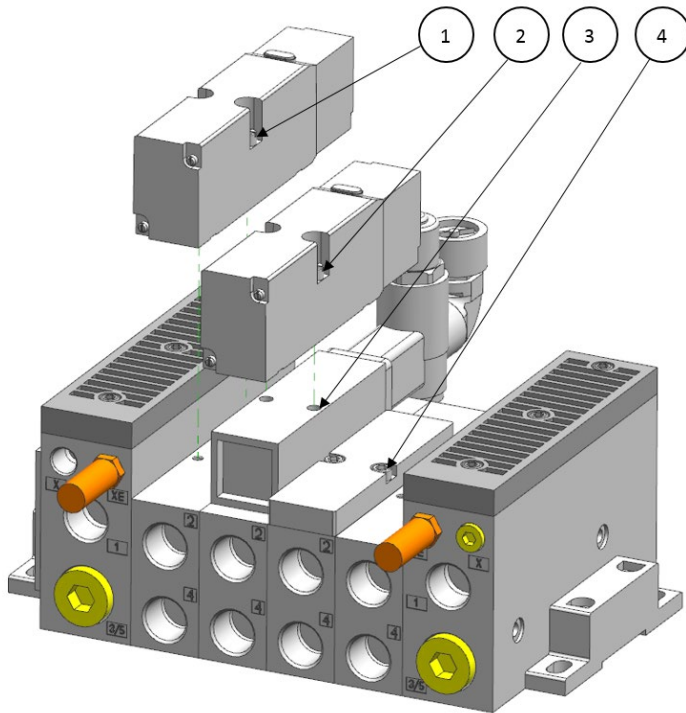

Table 35 – Numatics 2012 & 2035 Air Valve Assemblies

Fastener	Description	2012 Air Valve Assy		2035 Air Valve Assy	
		Torque		Torque	
		N-m	in-lb	N-m	in-lb
1	Valve to Manifold	0.9-1.1	8-10	2.5-2.8	22-25
2	Valve to Sandwich Plate	0.9-1.1	8-10	2.8-3.4	25-30
3	Sandwich Plate to Manifold	0.9-1.1	8-10	2.8-3.4	25-30
4	Blanking Plate to Manifold	1.4-1.7	12-15	2.8-3.4	25-30

## 17.10.2 TORQUE SPECIFICATIONS FOR NUMATICS ISO 1, 2 & 3 AIR VALVE ASSEMBLIES

Figure 6 – Numatics ISO 1, 2 & 3 Air Valve Assemblies

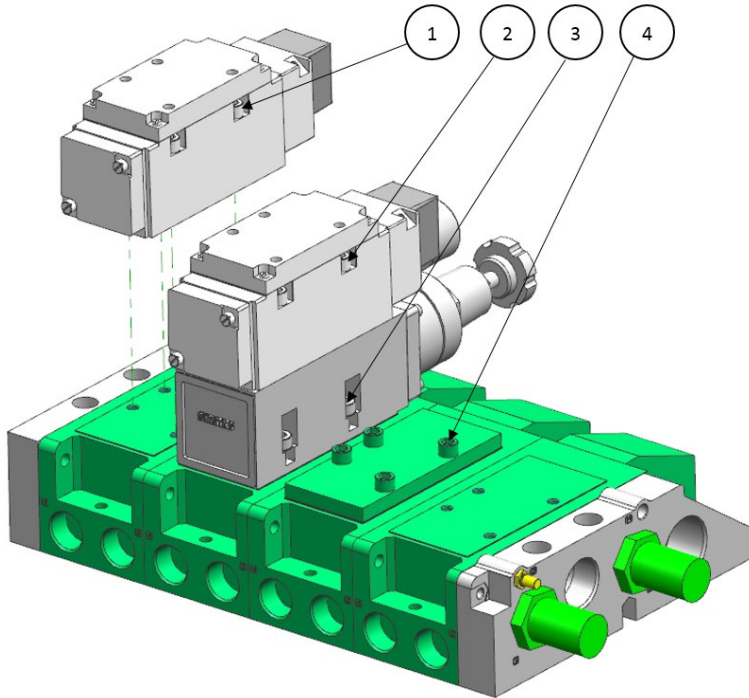



Table 36 – Numatics ISO 1, 2 & 3 Air Valve Assemblies

Fastener	Description	ISO 1, 2 & 3 Air Valve Assemblies	
		Torque	
		N-mm	in-lb
1	Valve to Manifold	3.6-4.3	32-38
2	Valve to Sandwich Plate	3.6-4.3	32-38
3	Sandwich Plate to Manifold	3.6-4.3	32-38
4	Blanking Plate to Manifold	3.6-4.3	32-38

## 17.11 HYDAC MALE PRESSURE TEST POINT

HPN 2638323 Hydac designation: 6003737 (9/16-18 UNF, 630 bar, 1620 series, O-ring/Form E)	Thread 9/16-18 UNF	25 ft-lb (35 N-m) (+10%, -0)
--	--------------------	---------------------------------

## 17.12 ACCUMULATOR GAS VALVES

HPN 9007755 Denenergy designation: AV500-4000	22 ft-lb (30 N-m) (+10%, -0)	
HPN 11862074 Denenergy designation: GV03-00	22 ft-lb (30 N-m) (+10%, -0)	

Note: Gas valves for standard accumulators, 4000psi

## 17.13 EV9 FLOW CONTROL VALVE

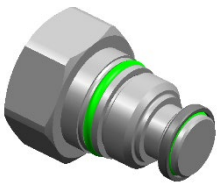
HPN 7610661 Sun Hydraulics designation: FXAAXAV 0.25 LPM (Liters Per Minute)	25 ft-lb (34 N-m) (+10%, -0)	
--	---------------------------------	---

Note: Fixed orifice, pressure compensated flow control valve, 5000psi

## 17.14 IGUS CFX CLAMPS

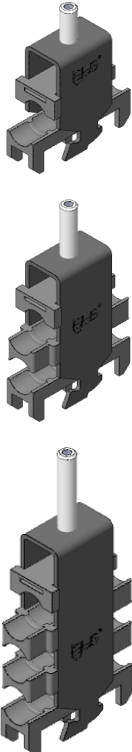
<table border="0"> <thead> <tr> <th>HPN</th> <th>Model #</th> </tr> </thead> <tbody> <tr><td>741401</td><td>CFX12.1</td></tr> <tr><td>741403</td><td>CFX12.2</td></tr> <tr><td>2200645</td><td>CFX12.3</td></tr> <tr><td>741400</td><td>CFX14.1</td></tr> <tr><td>741402</td><td>CFX14.2</td></tr> <tr><td>2295429</td><td>CFX14.3</td></tr> <tr><td>2143391</td><td>CFX16.1</td></tr> <tr><td>2200643</td><td>CFXL16.1</td></tr> <tr><td>741570</td><td>CFX16.2</td></tr> <tr><td>2206628</td><td>CFX16.3</td></tr> <tr><td>745860</td><td>CFX18.1</td></tr> <tr><td>742126</td><td>CFX18.2</td></tr> <tr><td>741399</td><td>CFX20.1</td></tr> <tr><td>2240786</td><td>CFX20.2</td></tr> <tr><td>745859</td><td>CFX22.1</td></tr> <tr><td>741569</td><td>CFX22.2</td></tr> <tr><td>747804</td><td>CFX26.1</td></tr> <tr><td>742128</td><td>CFX30.1</td></tr> <tr><td>6837530</td><td>CFX30.2</td></tr> <tr><td>7577891</td><td>CFXL30.2</td></tr> <tr><td>3623334</td><td>CFX38.1</td></tr> <tr><td>746702</td><td>CFX42.1</td></tr> </tbody> </table>	HPN	Model #	741401	CFX12.1	741403	CFX12.2	2200645	CFX12.3	741400	CFX14.1	741402	CFX14.2	2295429	CFX14.3	2143391	CFX16.1	2200643	CFXL16.1	741570	CFX16.2	2206628	CFX16.3	745860	CFX18.1	742126	CFX18.2	741399	CFX20.1	2240786	CFX20.2	745859	CFX22.1	741569	CFX22.2	747804	CFX26.1	742128	CFX30.1	6837530	CFX30.2	7577891	CFXL30.2	3623334	CFX38.1	746702	CFX42.1	1.1 ft-lb (1.5 N-m) (+10%, -0)	Single, double or triple clamp housings  
HPN	Model #																																															
741401	CFX12.1																																															
741403	CFX12.2																																															
2200645	CFX12.3																																															
741400	CFX14.1																																															
741402	CFX14.2																																															
2295429	CFX14.3																																															
2143391	CFX16.1																																															
2200643	CFXL16.1																																															
741570	CFX16.2																																															
2206628	CFX16.3																																															
745860	CFX18.1																																															
742126	CFX18.2																																															
741399	CFX20.1																																															
2240786	CFX20.2																																															
745859	CFX22.1																																															
741569	CFX22.2																																															
747804	CFX26.1																																															
742128	CFX30.1																																															
6837530	CFX30.2																																															
7577891	CFXL30.2																																															
3623334	CFX38.1																																															
746702	CFX42.1																																															



## 17.15 VIBRATION MOUNTS

Apply HGT-35 torque to all vibration mounts unless otherwise specified on assembly drawings or work instructions.

## 18 INTERNATIONAL STANDARDS TORQUE SPECIFICATIONS

The following torque values obtained from international standards are specified on the drawing when deviating from the Husky general torque standard.

### 18.1 ISO 6162:1994 - SPLIT FLANGE ASSEMBLIES

**Table 37 – Code 61 Split Flange Assemblies**

4 Bolt Split Flange Assemblies Code 61 (25 bar to 350 bar series)		
Bolt Size	Torque (+25% - 0) See Section 18.3	
	N-m	ft-lb
M8	25	18
M10	53	40
M12	95	70
M16	220	160
Lubricant	Lubriplate FGL-1 or Molykote G – rapid plus with MoS2	

**Table 38 – Code 62 Split Flange Assemblies**

4 Bolt Split Flange Assemblies Code 62 (400 bar series)		
Bolt Size	Torque (+25% - 0) See Section 18.3	
	N-m	ft-lb
M8	25	18
M10	53	40
M12	95	70
M14	150	110
M16	220	160
M20	390	290
Lubricant	Lubriplate FGL-1 or Molykote G – rapid plus with MoS2	

### 18.2 CAUTION

It is important that all screws be lightly torqued (e.g. from 1 to 2 FFFT) before applying the final recommended torque values to avoid breaking the flange halves during installation.

### 18.3 NOTES

- The recommended torque values are consistent with the HGT-50 general standard. Exception: M14 bolts (special size requiring a note on the drawing).
- The recommended torque values may be increased by 25% when flange head screws of property 12.9 screws are used with Unbrako Durlok-12.9 screws.

## 19 PET MOLD AND HOT RUNNER SPECIAL TORQUE SPECIFICATIONS

Following torque specifications must be applied accordingly to ensure proper installation.

## 19.1 CAM FOLLOWER TORQUE SPECIFICATIONS

Table 39 – CAM Follower Torque Specifications

CAM follower HPN	Component	Torque [N-m]	Torque [ft-lb]
1425388	Nut	22 N-m	16 ft-lb
1502548	Nut	87 N-m	64 ft-lb
2739013	Cam Follower	87 N-m	64 ft-lb
	Set Screw	8.5-9 N-m	6.3-6.6 ft-lb
5792862	Cam Follower	87 N-m	64 ft-lb
	Set Screw	8.5-9 N-m	6.3-6.6 ft-lb

## 19.2 EOAT TUBE RETAINER PIN TORQUE SPECIFICATION

Figure 7 – EOAT Tube Retainer Pin Torque Specification

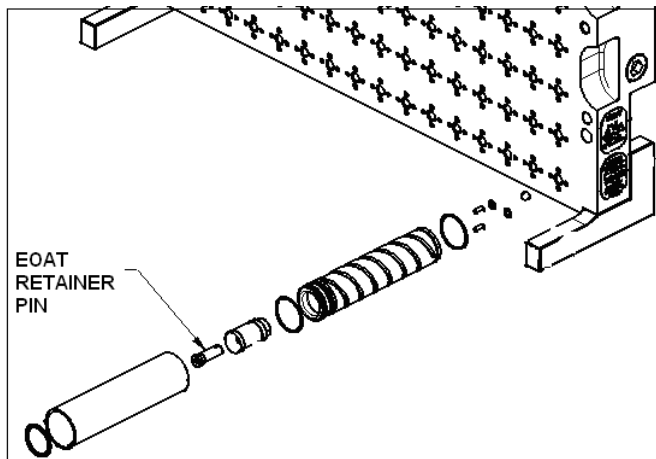

Table 40 – EOAT Tube Retainer Pin Torque Specification

Hex Size (mm)	Torque (N-m)	Torque (ft-lb)
5	37	27
4	20	15

## 19.3 COOLPIK VACUUM/BLOW PIN TORQUE SPECIFICATIONS

Table 41 – COOLPIK Vacuum/Blow Pin Torque Specifications

Vacuum/Blow Pin Size	Torque	
	N-m	ft-lb
M6	2	1.4
M12	15	11
M16	34	25

M20	60	44
-----	----	----

## 19.4 COOLPIK MOVING PUCK INSTALLATION TORQUE SPECIFICATION

Apply following torque during moving puck installation.

**Figure 8 – Moving Puck Assembly Installation Torque Specification**

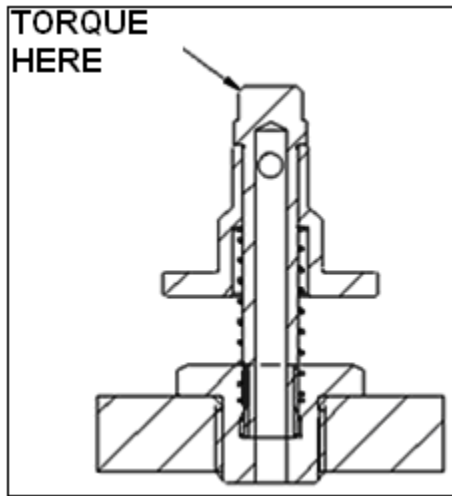

Torque the sub-assembly into the COOLPIK plate to 18 N-m through the top of the pin using an 8mm socket.

## 19.5 COOLPIK PLATE MOUNTING TORQUE SPECIFICATION

Apply HGT-80 [77N-m (56.8 lb-ft)] torque for M10 COOLPIK plate mounting screws.

**Figure 9 – COOLPIK Assembly on Machine Plenum**

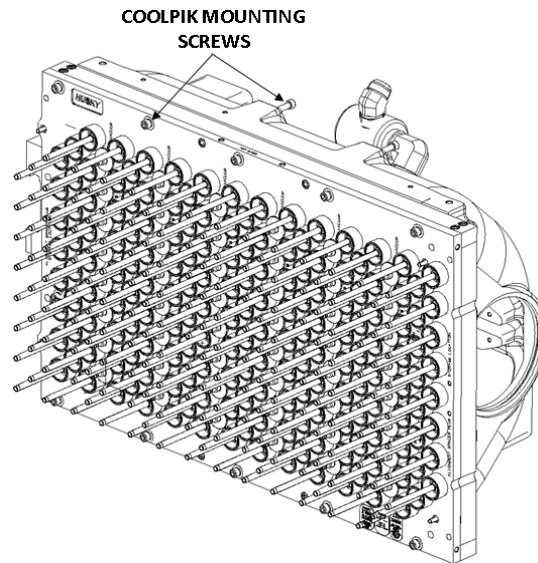

## 19.6 MOLD/HOT RUNNER LIFT BARS MOUNTING SCREWS TORQUE APPLICATIONS

Table 42 – Mold/Hot Runner Lift Bars Mounting Screws Torque Specifications

Application		Hardware		Base/Threaded Material	Torque Standard
Mechanical	• Hot Runner/Mold Lift Bars Mounting Screws (Excluding M30 and Larger)	Screws and Threaded Rods	- DIN 912-12.9 SHCS - DURLOK-12.9-UNB HHS - DIN 933 & 931-10.9 HHCS - DIN 976-12.9&10.9 ROD - ASTM A574 SHCS	Steel Cast Iron	HGT-50
	• Hot Runner/Mold Lift Bars Mounting Screws, M30 and Larger Sizes	Screws and Threaded Rods	- DIN 912-12.9 SHCS - DURLOK-12.9-UNB HHS - DIN 933 & 931-10.9 HHCS - DIN 976-12.9&10.9 ROD - DIN 7991-10.9 FHCS - ISO 7380-10.9 BHCS - ASTM A574 SHCS	Any Material for Lift Bar Mounting Screws	HGT-35

## 19.7 GIB/WEAR PLATE MOUNTING SCREWS TORQUE SPECIFICATION

Apply HGT-50 on Gibs and Wear Plates.

Apply HGT-LHCS for Wear Plates using LHCS.

## 19.8 NECK RING PLUGS TORQUE SPECIFICATION

Apply appropriate torque to the Neck Ring plugs according to the table below.

Table 43 – Neck Ring Plugs Torque Specifications

HPN	Size	Material	Maximum Tightening Torque (+ 10% / - 10%)	
			N-m	ft-lb
4125714	M5	Brass	1.5	1.1
6359476	1/16	Brass	7	5.2

## 19.9 STACK INSERTS TORQUE SPECIFICATION

Apply HGT-80 on all SHCS's that are used on Stack Inserts.

### **19.10 TORQUE SPECIFICATION FOR WATER MANIFOLDS TO SLIDES**

Apply HGT-80 on all SHCS's that are used to mount Slide Water Manifolds to Slides.

### **19.11 TORQUE SPECIFICATION FOR SLIDE TO CONNECTING BARS**

Apply HGT-80 on all SHCS's that are used to mount Slides to Connecting Bars.

### **19.12 TORQUE SPECIFICATION FOR EOAT ASSY. TO ROBOT**

Apply HGT-80 on all SHCS's that are used to mount EOAT Assembly to Robot Carriage.

### **19.13 TORQUE SPECIFICATION FOR NEXPET CORE SLEEVE SET SCREWS**

**Figure 10 – Torque Specification for NexPET Core Sleeve Set Screws**

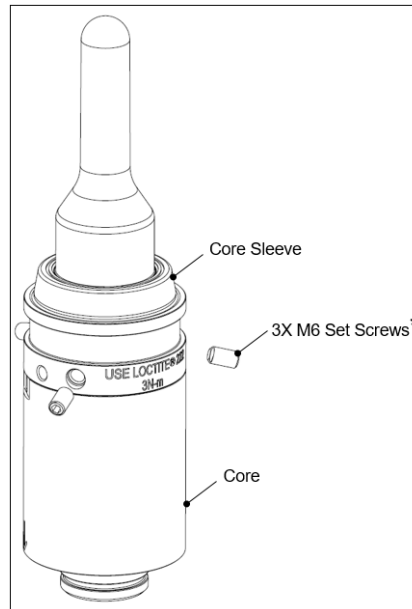

\*Apply LOCTITE® 222 or equivalent to the set screws and tighten them to 3N-m [2.2 lb-ft] – refer to NexPET mold manual for detailed installation instructions.

## **20 APPENDIX**

<b>HUSKY</b>	HS 252 - STANDARD ASSEMBLY TORQUES		Page	38 of 50
	Revision Level - 79 - PUBLISHED	Security Level - PUBLIC	Standard No.	HS 252

***20.1 DLO DEVICE DETAILS (2205)***

Refer to the following sheets (See 6 to 17) for DLO device torque values.

## 3VA Breakers

BREAKERS		BREAKER LUGS			MOUNTING BOLTS		UNINSULATED FERRULES				FLEXIBLE BUSBAR				COMPRESSION LUGS / BUSBAR				
Type	SIZE (A)	Type	HPN	# of Conn.	Torque b-in	Torque N-m	AWG	Strip (mm)	AWG	Torque b-in	Torque N-m	Max Width (mm)	Thickness (mm)	Torque b-in	Torque N-m	Max W x D (mm)	Bolt Size	Torque b-in	Torque N-m
3VA51	15-125	3VA9133-0JA11	10915876	1	N/A		14 - 1/0	12	14 - 6	44	5	13	1 - 7.2	71	8	N/A			
		3VA9134-0JA11	10973718	2					4 - 1/0	71	8								
		3VA9133-0JF60	10915905	2	71	8	14 - 4	12	14 - 8	53	6	N/A							
		3VA9134-0JF60	10973732	2				24	6 - 4	62	7								
						39													
3VA52	70-250	3VA9233-0JA11	10943437	1	N/A		10 - 3/0	19	10 - 4	53	6	20	1 - 6	89	10	N/A			
		3VA9234-0JA11	10973757	2					2 - 3/0	89	10								
		3VA9233-0JA12	10943456	1	N/A		4 - 3/3	20	4 - 2	71	8	20	3.2 - 6	106	12	N/A			
		3VA9234-0JA12	10973768	2					1 - 3/3	142	16								
3VA9233-0JF60	10915946	2	177	20	14 - 4	15	14 - 8	53	6	N/A									
3VA9234-0JF60	10973778	2				26	6 - 4	62	7										
						39													
3VA53	300-400	3VA9473-0JA13	11002426	1	N/A		2 - 3/3	26	2 - 3/0	142	16	24	2 - 10	248	28	N/A			
		3VA9474-0JA13	11039865	2					4/0 - 3/3	248	28								
		3VA9473-0JJ23	11002455	1	355	40	2/0 - 3/3	31	2/0 - 3/3	450	51	N/A							
		3VA9474-0JJ23	11039876	1				58											
3VA9373-0JF60	10973808	3	355	40	14 - 4	18	14 - 8	53	6	N/A									
3VA9374-0JF60	10973814	3				35	6 - 4	62	7										
3VA54	450-600	3VA9473-0QA00	11002457	1	N/A		N/A				N/A				35 x 10	M10	355	40	
		3VA9474-0QA00	11039884	2															
3VA55	600-800	3VA9573-0JB23	11039991	2	275	31	4/0 - 3/3	26	4/0 - 3/3	375	42.5	N/A				N/A			
		3VA9574-0JB23	11040004	3															
		3VA9673-0JB32	11050762	3	275	31	4/0 - 262	26	4/0 - 262	225	25.5	N/A				N/A			
		3VA9674-0JB32	11050778	2															
3VA9673-0JJ43	11050763	2	375	42.5	4/0 - 3/3	23	4/0 - 3/3	325	36.5	N/A				N/A					
3VA9674-0JJ43	11050780	2				45													
		3VA9673-0QA00	11050770	1	N/A		N/A				N/A				50 x 10	M10 x1 M10 x2	275	31	
		3VA9674-0QA00	11050771	2															

#

BUSBAR MOUNTING ADAPTORS								
Manufacturer	Part #	HPN	# of Conn.	MOUNTING BOLTS	Torque		Torque	
					l-in	N-m	l-in	N-m
Wohner	32981	6077583	1	MOUNTING BOLTS	1.8	0.2	Preinstalled 4 AWG wire leads	
Siemens	8US1213-4AP03	10915871	1		71	8	89	10
	8US1313-4AH03	10943617	1		106	12	177	20
8US1213-4AH04	10943611	1						
8US1313-4AM04	11039967	1						

BUSBAR CONNECTION ADAPTORS								
Manufacturer	Part #	HPN	# of Conn.	AWG	Max Busbar (mm)	Strip (mm)	Torque	
							l-in	N-m
Wohner	01069	6251136	1	N/A	30 x 10	35	133	15
	01538	5960823	1	N/A	30 x 10	45	266	30
	01147	7861105	1	3/0 - 373	N/A	45	266	30
	01240	6679232	1	10 - 2/0	N/A	25	80	9
	01243	6257177	1	6 - 4/0	N/A	25	120	13.5
	32146	8010682	2	12 - 6	N/A	15	27	3



**DISTRIBUTION BLOCKS**

Manufacturer	Part #	HPN	POSITION	# of Conn.	AWG	Strip (mm)	AWG	Torque l-b-in	N-m	
Cooper Bussman	PDBFS303	6770277	Line / Load	1	4 - 313	32	4 - 313	275	31	
	PDBFS330	5626032	Line	1	4 - 373	32	4 - 373	500	56.5	
			Load	Row 1	3	14 - 4	30	6 - 4	45	5
				Row 2	3		15	8	40	4.5
							14 - 10	35	4	
	PDBFS377	6197174	Line		2	4 - 262	30 36	4 - 262	275	31
				Load	Row 1	4	14 - 6	32	6	35
			Row 2		4	26		8	25	2.8
			Row 3	4	15	14 - 10	20	2.3		
	PDBFS500	7500450	Line / Load	2	4 - 313	32	4 - 313	275	31	
PDBFS504	7500471	Line / Load	2	4 - 373	32	4 - 373	500	56.5		
16371-1 16371-3	5002820 2246870	Line		1	4 - 313	25	4 - 313	275	31	
		Load	Row 1	3	14 - 2	25	* 14 - 2	120	13.5	
			Row 2	3	14 - 6	16	6 - 4	45	5	
			Row 3	3		12	8	40	4.5	
						14 - 10	35	4		
16377-2 16377-3	4162385 4155603	Line	Row 1	1	4 - 4/0	25	4 - 4/0	275	31	
			Row 2	1		32				
		Load	Row 1	4	14 - 6	25	6	35	4	
			Row 2	4		16	8	25	2.8	
Row 3	4	12	14 - 10	20	2.3					
16528-1 16528-3	3007511 2466523	Line		2	2 - 373	45	2 - 373	500	56.5	
		Load	Row 1	2	6 - 2/0	32	* 6 - 2/0	120	13.5	
				2	14 - 6		6	35	4	
			Row 2	2	6 - 2/0	16	8	25	2.8	
						14 - 10	20	2.3		

\* Larger termination screws

**DISTRIBUTION BLOCKS**

Manufacturer	Part #	HPN	POSITION	# of Conn.	AWG	Strip (mm)	AWG	Torque l-b-in	N-m	
Weidmueller	7942923	10 285 000 000	Line	1	M10	N/A	N/A	133	15	
			Load	1						
Marathon	8235602	1 333 97 51 CH	Line	1	2 - 373	40	6 - 373	375	42.4	
			Load	Row 1	2	14 - 1	32	6 - 1	120	13.5
				Row 2	2		16	8	40	4.5
									14 - 10	35
Ferraz Shawmut	63131	7147588	Line	1	14 - 1/0	17	6 - 1/0	120	13.5	
			Load	Row 1	2	14 - 6	22	6	35	4
				Row 2	2		10	8	25	2.8
									10 - 14	20

Refer to HS 252 for Mechanical Torque specifications

CONTACTORS												
Manufacturer	Size	Part #	HPN	# of Conn.	Ferrules		FLEXIBLE BUSBAR		LUGS / BUSBAR		Torque	
					AWG	Strip (mm)	Max Width (mm)	Thickness (mm)	Max Width (mm)	Bolt Size	b-in	N-m
Siemens	S2 3RT203	BOX LUGS ATTACHED	2600404	1	18 - 2	13	N/A	N/A	N/A	35	4	
				2	18 - 4							
Siemens	S3 3RT204	BOX LUGS ATTACHED	2600404	1	14 - 1	17	9	2.4 - 4.8	N/A	44	5	
				2	14 - 2							
Siemens	S6 3RT105	WITHOUT BOX LUGS	2600407	N/A		N/A		15	M6	97	11	
				1	6 - 262	20	15.5	2.4 - 8				
Siemens	S10 3RT106	WITHOUT BOX LUGS	2600408	N/A		N/A		17	M8	177	20	
				1	3/0 - 373	27	24	4.8 - 10	N/A			
Siemens	S12 3RT107	WITHOUT BOX LUGS	2600408	N/A		N/A		25	M10	177	20	
				1	3/0 - 373	27	24	4.8 - 10	N/A			

WIRE GAGE	
AWG	mm <sup>2</sup>
26	0.14
24	0.25
22	0.34
20	0.5
19	0.75
18	1.0
16	1.5
14	2.5
12	4
10	6
8	10
6	16
4	25
2	35
1	50

OVERLOAD RELAYS												
Manufacturer	Size	Part #	HPN	# of Conn.	Ferrules		LUGS / BUSBAR		Torque			
					AWG	Strip (mm)	Max Width (mm)	Bolt Size	b-in	N-m		
Siemens	S2 3RU213	BOX LUGS ATTACHED	2600404	1	18 - 2	13	N/A	N/A	35	4		
				2	18 - 4							
Siemens	S3 3RU214	BOX LUGS ATTACHED	2600404	1	14 - 1	17	N/A	N/A	44	5		
				2	14 - 2							
Siemens	S6 3RB205	WITHOUT BOX LUGS	2600407	N/A		N/A		15	M8	97	11	
				1	6 - 262	20	15.5	2.4 - 8				
Siemens	S10 3RB206	WITHOUT BOX LUGS	2600408	N/A		N/A		25	M10	177	20	
				1	3/0 - 373	27	24	4.8 - 10	N/A			

STUD SIZE	
USA	METRIC
#2	M2
#4	M2.5
#5	M3
#6	M3.5
#8	M4
#10	M5
1/4"	M6
5/16"	M8
3/8"	M10
7/16"	M11
1/2"	M12
5/8"	M16

Refer to HS 252 for Mechanical Torque specifications



MACHINE MODEL  
**UNIVERSAL MASTER**

	Name	Date	Time
Edited	dleebo	8/15/2019	9:31:53 AM
Appr			
Checked			
Original			

DESCRIPTION  
**DLO DEVICE DETAILS**

PROJECT	- WIRE	+
MACHINE		
DRAWING NO. <b>UNIVERSAL MASTER</b>	Sheet <b>9</b>	Total <b>23</b>

**MOTOR STARTER PROTECTORS**

					Ferrules		LUGS / BUSBAR			
Manufacturer	Size	Part #	HPN	# of Conn.	AWG	Strip (mm)	Max Width (mm)	Bolt Size	Torque l-b-in N-m	
Siemens	S2 3RV203	BOX LUGS ATTACHED		1	18 - 2	13	N/A		35	4
				2	18 - 4					
	S3 3RV204 3RV274	BOX LUGS ATTACHED		1	14 - 1	17	N/A		44	5
				2	14 - 2					
	WITHOUT BOX LUGS				N/A		15	M6		

**MACHINE / MOLD HEATS**

					Ferrules		LUGS / BUSBAR			
Manufacturer	Type	Part #	HPN	# of Conn.	AWG	Strip (mm)	Max Width (mm)	Bolt Size	Torque l-b-in N-m	
Siemens	SSY4	(1,2,3)-Pole		2	14 - 4	15	N/A		27	3
	SITOP	6EP1437-3BA10 6EP4137-3AB00	8098974 7829488	2	14 - 6	12			11	1.2
Wohner	AES-CC	31298	4985144	1	14 - 8	11			20	2.3
		31299	4985089		6 - 4				25	2.8
	31300	4986413								
	CTB-T35	31550	4985169	1	10 - 1/0	15		50	5.6	
ABA	6 Slot	ICC3.2	7869129	1	N/A		15	M5	20	2.3

**PE CONNECTIONS**

Manufacturer	Part #	HPN	# of Conn.	AWG	Strip (mm)	Bolt Size	Torque l-b-in N-m	
Brumall	1024-R0	2172625	1	6 - 262	22	N/A	375	42.4
			24	8	10		40	4.5
				14 - 10			35	4
Hoffman	10 Hole PE busbar	2617195	8	N/A		M8	89	10
			2			M10	177	20
	6 Hole PE busbar	3086616	3	N/A		M8	89	10
			3			M10	177	20
	PE stud	N/A	1	N/A		M6	20	2.3

Refer to HS 252 for Mechanical Torque specifications

#

**LINE FILTERS**

				POWER CONNECTIONS					PE CONNECTION			
Manufacturer	Part #	HPN	Size	max. AWG	Strip (mm)	Bolt Size	Torque		Bolt Size	Torque		
							b-in	N-m		b-in	N-m	
BAUMULLER (A211)	BFN 3-1-030-001	2351717	30A	8	9	N/A	9	1	M5	18	2	
	BFN 3-1-042-001	2351719	42A									
	BFN 3-1-056-001	2351721	56A	6	10		15	1.7	M6	35	4	
	BFN 3-1-075-001	2351722	75A									
	BFN 3-1-100-001	2351723	100A	1	24		62	7	M10	53	6	
	BFN 3-1-130-001	2351724	130A									
	BFN 3-1-180-001	2351726	180A	3/0	27		142	16				
	BFN 3-1-250-001	4683445	250A									
	BFN 3-1-270-001	2620271	270A	N/A			M10	142	16		142	16
	BFN 3-1-320-101	4570913	320A				M12	221	25		53	6
	BFN 3-1-400-101	4684162	400A			M10	142	16	Same as POWER CONNECTIONS			
BFN 3-1-600-101	4684158	600A										
SIEMENS (A211)	6SL3000-0BE21-6DA0	5157016	16kW	8	10	N/A	15	1.7	M6	53	6	
	6SL3203-0BE31-1BA0	7375741	37kW	2	24	N/A	62	7	M10	89	10	
	6SL3203-0BE32-5AA0	6884295	132kW	N/A		M10	221	25	N/A			

WIRE GAGE	
AWG	mm <sup>2</sup>
26	0.14
24	0.25
22	0.34
20	0.5
19	0.75
18	1.0
16	1.5
14	2.5
12	4
10	6
8	10
6	16
4	25
2	35
1	50

STUD SIZE	
USA	METRIC
#2	M2
#4	M2.5
#5	M3
#6	M3.5
#8	M4
#10	M5
1/4"	M6
5/16"	M8
3/8"	M10
7/16"	M11
1/2"	M12
5/8"	M16

Refer to HS 252 for Mechanical Torque specifications

#

LINE REACTORS													
				POWER CONNECTIONS					PE CONNECTION				
Manufacturer	Part #	HPN	Size	max. AWG	Strip (mm)	Bolt Size	Torque		Bolt Size	Torque			
							l-b-in	N-m		l-b-in	N-m		
BAUMULLER (A218)	BK3-0040/0050-002	6344019	40A	6	15	N/A	9	3	M6	53	6		
	BK3-0065/0080-002	11005628	65A	4	18								
	BK3-0080/0100-002	11005647	80A	1	24		53	6					
	BK3-0115/0140-002	11005650	115A										
	BK3-0065/0080-001	5831222	65A	N/A		M6	53	6	M6	53	6		
	BK3-0080/0100-001	5831202	80A			M8	106	12					
	BK3-0115/0140-001	4922039	115A			M10	133	15	M8	106	12		
	BK3-0165/0200-001	4684155	165A										
	BK3-0195/0240-001	4921887	195A										
	BK3-0275/0340-001	4121316	275A			M12	177	20					
	BK3-0365/0450-001	4420121	365A										
	BK3-0450/0550-001	4922113	450A										
	BK3-0615/0750-001	4684150	615A										
	SIEMENS (A194)	6SL3000-0DE21-6AA0	4858572			16 kW	6	14	N/A	11	1.2	Same as POWER CONNECTIONS	
6SL3000-0DE23-6AA0		4858565	36 kW			2	19	22		2.5			
6SL3000-0DE25-5AA1		3687230	55 kW	1/0	24	62	7						
6SL3000-0DE28-0AA1		4858569	80 kW	4/0	35	SPRING CLAMP		M10	221	25			
6SL3000-0DE31-2AA1		4858567	120 kW										

WIRE GAGE	
AWG	mm <sup>2</sup>
26	0.14
24	0.25
22	0.34
20	0.5
19	0.75
18	1.0
16	1.5
14	2.5
12	4
10	6
8	10
6	16
4	25
2	35
1	50

STUD SIZE	
USA	METRIC
#2	M2
#4	M2.5
#5	M3
#6	M3.5
#8	M4
#10	M5
1/4"	M6
5/16"	M8
3/8"	M10
7/16"	M11
1/2"	M12
5/8"	M16

Refer to HS 252 for Mechanical Torque specifications

#

ACTIVE INTERFACE MODULES												
				POWER CONNECTIONS					PE CONNECTION			
Manufacturer	Part #	HPN	Size	max. AWG	Strip (mm)	Bolt Size	Torque		Bolt Size	Torque		
							b-in	N-m		b-in	N-m	
SIEMENS (A195)	6SL3100-0BE21-6AB0	4959543	16 kW	6	14	N/A	15	1.7	M8	115	13	
	6SL3100-0BE23-6AB0	5854353	36 kW	1/0	24		53	6				
	6SL3100-0BE25-5AB0	4021256	55 kW									
	6SL3100-0BE28-0AB0	4021251	80 kW	N/A		M8	115	13				
	6SL3100-0BE31-2AB0	4021250	120 kW									

WIRE GAGE	
AWG	mm <sup>2</sup>
26	0.14
24	0.25
22	0.34
20	0.5
19	0.75
18	1.0
16	1.5
14	2.5
12	4
10	6
8	10
6	16
4	25
2	35
1	50

ACTIVE LINE MODULES													
				POWER CONNECTIONS					PE CONNECTION			DC LINK BUSBAR	
Manufacturer	Part #	HPN	Size	max. AWG	Strip (mm)	Bolt Size	Torque		Bolt Size	Torque		Torque	
							b-in	N-m		b-in	N-m	b-in	N-m
SIEMENS (A20)	6SL3130-7TE21-6AA4	4959545	16 kW	8	12	N/A	15	1.7	M5	27	3	15.9	1.8
	6SL3130-7TE23-6AA3	5682121	36 kW	N/A		M6	53	6	M6	53	6		
	6SL3130-7TE25-5AA3	5808068	55 kW	N/A		M8	115	13	M8	115	13		
	6SL3131-7TE25-5AA3	7260842											
	6SL3130-7TE28-0AA3	3890439	80 kW	N/A		M8	115	13	M8	115	13		
	6SL3131-7TE28-0AA3	6849701											
	6SL3130-7TE31-2AA3	3869320	120 kW	N/A		M8	115	13	M8	115	13		
6SL3131-7TE31-2AA3	6849702												
6SL3162-2BM01-0AA0	3869348	DC link	4/0	25	N/A	115	13	N/A					

STUD SIZE	
USA	METRIC
#2	M2
#4	M2.5
#5	M3
#6	M3.5
#8	M4
#10	M5
1/4"	M6
5/16"	M8
3/8"	M10
7/16"	M11
1/2"	M12
5/8"	M16

Refer to HS 252 for Mechanical Torque specifications

SERVO DRIVES													
				POWER CONNECTIONS					PE CONNECTION			DC LINK BUSBAR	
Manufacturer	Part #	HPN	Size	max. AWG	Strip (mm)	Bolt Size	Torque		Bolt Size	Torque		Torque	
							b-in	N-m		b-in	N-m	b-in	N-m
BAUMULLER (209)	BM4434 BM4435	8425222 8425223	40A 60A	4	16	N/A	18	2	Same as POWER CONNECTIONS	N/A			
	BM4443	8425143	80A	1	24	N/A	62	7					
	BM4444	8098421	100A										
	BM4445	8098423	130A										
	BM4446	8098425	150A										
	BM4453	8098510	150A	N/A		M8	106	12					
	BM4454	8098511	210A										
	BM4462	8098635	250A	M10	133	15							
	BM4463	8098636	300A										
	BM4466	8098637	350A										
	BM4472	8098684	450A										
BM4473	8098685	594A											
SIEMENS (A23) (A235) (A41, A42) (A55)	6SL3120-1TE24-5AA3 6SL3121-1TE24-5AA3	3869422 7260827	45 A	N/A		M6	53	6	M6	53	6	15.9	1.8
	6SL3120-1TE26-0AA3 6SL3121-1TE26-0AA3	4870136 6849696	60 A										
	6SL3120-1TE28-5AA3 6SL3121-1TE28-5AA3	4054901 6849698	85 A			M8	115	13	M8	115	13		
	6SL3120-1TE31-3AA3 6SL3121-1TE31-3AA3	4054899 6849699	132 A										
	6SL3120-1TE32-0AA4 6SL3121-1TE32-0AA4	3869421 6849700	200 A										
	6SL3210-1PE27-5UL0	7251771	37 kW	2	18	N/A	35	4					
	6SL3210-1PE31-1UL0	7251769	55 kW	2/0	25	N/A	80	9					
	6SL3210-1PE31-8UL0	7162332	90 kW	N/A		M10	212	24					
	6SL3210-1PE32-5UL0	6852710	132 kW										

WIRE GAGE	
AWG	mm <sup>2</sup>
26	0.14
24	0.25
22	0.34
20	0.5
19	0.75
18	1.0
16	1.5
14	2.5
12	4
10	6
8	10
6	16
4	25
2	35
1	50

STUD SIZE	
USA	METRIC
#2	M2
#4	M2.5
#5	M3
#6	M3.5
#8	M4
#10	M5
1/4"	M6
5/16"	M8
3/8"	M10
7/16"	M11
1/2"	M12
5/8"	M16

Refer to HS 252 for Mechanical Torque specifications

#

SERVO MOTORS					POWER CONNECTIONS			PE CONNECTION			
Manufacturer	Part #	HPN	Motor Size	Terminal Box #	Bolt Size	Torque l-b-in	N-m	Bolt Size	Torque l-b-in	N-m	Cable Entry Ø
BAUMULLER	DS2-100LO54W-20-5	8008538	100	12	M8	53	6	Same as POWER CONNECTIONS	M40 x 1 M25 x 1		
	DS2-100KO54W-30-5	8008324									
	DS2-100MO54W-30-5	8008338									
	DS2-100BO54W-20-5	8008540 8135668		14							
	DS2-100LO54W-30-5	8008350									
	DS2-100BO54W-30-5	8008351 8012949									
	DS2-132MO54W-20-5	8025038	132	22	M10	89	10		M40 x 2 M25 x 1		
	DS2-132ML54W-30-5	8008355 8010220		24					M63 x 2 M25 x 1		
	DS2-132MO54W-30-5	8008356 8012948									
	DS2-132LO54W-30-5	8008354		26							
	DS2-132BO54W-30-5	8008353 8012942									
	DS2-160KO54W-30-5	8012944							160	32	64 x 2 25.5 x 1
	DS2-160MO54W-30-5	8008366 8012945	34	M12	89	15.5	76 x 2 25.5 x 1				
	DS2-160LO54W-30-5	8008358 8012946									
	DS2-160BO54W-30-5	8008357 8012947									
	DS2-200LO54W-27-5	8020273	200	46	M16	89	10		51 x 6 25.5 x 1 40.5 x 2		
	DS2-200MO54W-27-5	8020002									

WIRE GAGE	
AWG	mm <sup>2</sup>
26	0.14
24	0.25
22	0.34
20	0.5
19	0.75
18	1.0
16	1.5
14	2.5
12	4
10	6
8	10
6	16
4	25
2	35
1	50

STUD SIZE	
USA	METRIC
#2	M2
#4	M2.5
#5	M3
#6	M3.5
#8	M4
#10	M5
1/4"	M6
5/16"	M8
3/8"	M10
7/16"	M11
1/2"	M12
5/8"	M16

Refer to HS 252 for Mechanical Torque specifications



#

PUMP MOTORS

[Data Sheets](#)

		POWER CONNECTIONS					PE CONNECTION							
Manufacturer	HP	# of Conn.	AWG	Strip (mm)	Bolt Size	Torque l-b-in N-m		AWG	Strip (mm)	Torque l-b-in N-m		Cable Entry Ø		
EMOD	20 - 60	6	N/A		M8	53	6	10 - 1/0	20	71	8	Pg13 x 7 Pg11 x 2		
	60 - 100											Pg16 x 7 Pg11 x 2		
	100 - 125	6			M10	89	10	1 - 3/73					Pg21 x 7 Pg11 x 2	
	125 - 150	6			M12	137	15.5							
	200 - 250	6			4 - 4/0	35	N/A	Cage Clamp *		Same as POWER CONNECTIONS				M40 x 7 M20 x 1
	200 - 600	12												M32 x 13 M20 x 1

\* WAGO TYPE 285-195 -> USE BARE DLO (NO STOPPER)

WIRE GAGE	
AWG	mm <sup>2</sup>
26	0.14
24	0.25
22	0.34
20	0.5
19	0.75
18	1.0
16	1.5
14	2.5
12	4
10	6
8	10
6	16
4	25
2	35
1	50

STUD SIZE	
USA	METRIC
#2	M2
#4	M2.5
#5	M3
#6	M3.5
#8	M4
#10	M5
1/4"	M6
5/16"	M8
3/8"	M10
7/16"	M11
1/2"	M12
5/8"	M16

Refer to HS 252 for Mechanical Torque specifications



MACHINE MODEL

UNIVERSAL MASTER

	Name	Date	Time
Edited	dleeTwo	2/4/2022	11:56:50 AM
Appr			
Checked			
Original			

DESCRIPTION

DLO DEVICE DETAILS

PROJECT

MACHINE

DRAWING NO.

UNIVERSAL MASTER

-WIRE +

Sheet Total

16 23

1 2 3 4 5 6 7 8 9 10 11 12 13 14 15 16 17 18 19

CLASS A --> Electrical threaded connections (>30A)	
#	Connection Type
1	DLO Conductors
2	Non DLO Conductors (>=8AWG)
3	Flexible Busbars
4	Busbar Connection / Mounting Adaptors
5	Comb-Type Busbars
6	SINAMICS DC Link busbars
7	Main Breaker Lug Mounting Bolts

**CLASS A NOTES:**

All Class A connections shall use Torque Record Report

**CLASS A TORQUERECORD REPORT**

Lookup torque values must be predefined prior to assembly  
 Operator to record name for each torqued connection point  
 Inspector to record name for each verification point  
 This report is a CTQ supplier deliverable  
 This report will be available for post build reference  
 Refer to SMVI-2551

**Torque value reference:**

1. Husky DLO Tables
2. HS252
3. Specials -> OEM installation guide

CLASS B --> Electrical threaded connections (<=30A)	
#	Connection Type
1	Non DLO Conductors (<=10AWG)
2	Distribution Blocks (load side)
3	SSY Circuit Breakers
4	AES-CC Fuse holders
5	Control Transformers *
6	DC power supplies *
7	Buffer Module *
8	RV surge suppressors *
9	Outlets *
10	Control Relays *
11	Heat Exchangers *
12	Grounding Studs
13	Bonding Straps

**CLASS B NOTES:**

All Class B connections shall be tightened and tug tested

\* Future design change to spring cage terminals

CLASS C --> Device Mounting	
#	Mounting Type
1	Busbar supports
2	Busbar Adaptors
3	Breakers
4	Breaker Handles
5	Distribution Blocks
6	Contactors
7	Line Filters
8	Line Reactors
9	Servo Drives
10	Heat Sink
11	Solid State Relays
12	Aluminum Components
13	IPC / Battery
14	Din Rail
15	Wire Duct
16	Connector bulkheads / hoods
17	Strain Relieves / Gland Plates
18	Enclosure - Accessories
19	Adaptor plates
20	Current Transformers